



BRIGHTWELL®

BRIGHTFLOW® CHEMICAL DISPENSING SYSTEMS

BrightFlush®

ENZYME & BACTERIA DOSING SYSTEM

Operation

The BrightFlush Sanitising system is suitable for installation where the dispenser and cistern are located in a service corridor or roof space, to avoid chemical hazard to the public.

This dispenser can accommodate timed doses of a single product between 1 and 60 seconds. These doses are automatically triggered by the flushing of the cistern.

Installation Diagram

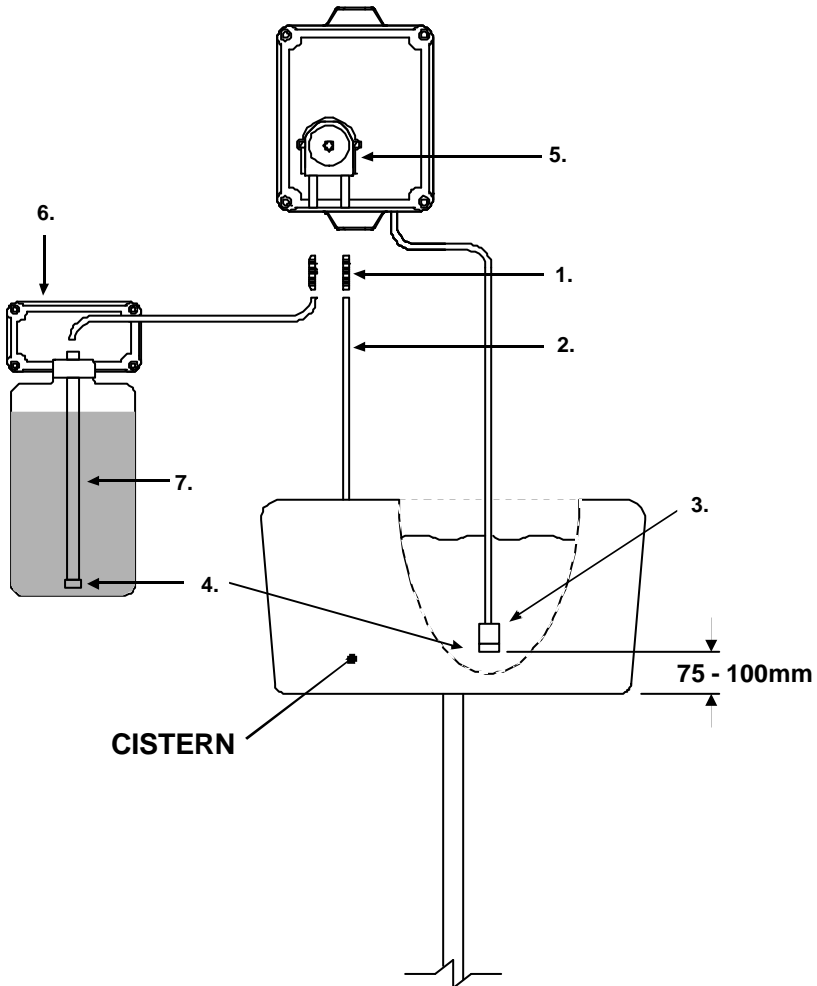

-
1. **4x4 Hose Connector. SBF1630 (10PK)**
 2. **4x6 PVC Tube. SBF1240 (6 mtr)**
 3. **Stainless Steel weight. SBF1241 (4PK)**
 4. **Sinker Support. SBF1242 (4PK)**
 5. **Mini Pumphead. Silicone - SBF1000 (2PK)**
Viton (Mains only) - SBF1002 (2PK)
 6. **Off the Floor System (Optional) - 5110**
 7. **Stiffener Tube. SBF1204 (4PK)**

Mains Unit

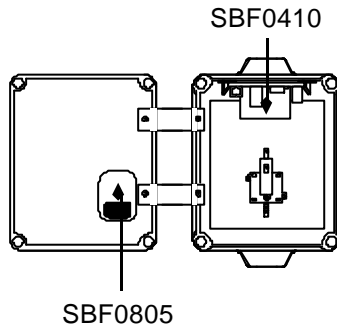

Battery Unit

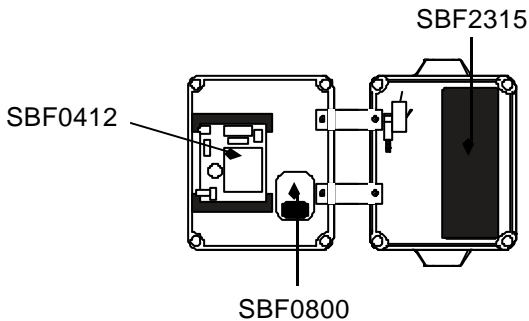

Wiring

Mains Unit

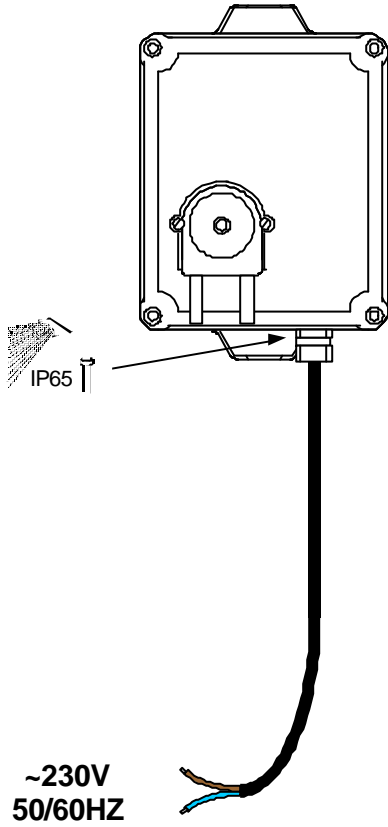

Battery Unit

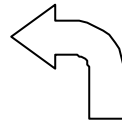
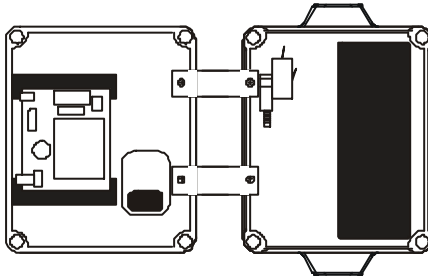
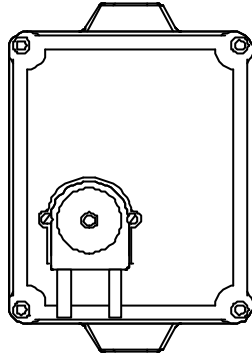

8 x D-Cell



Setting Run Time

Minimum = 1 second

Maximum = 60 seconds

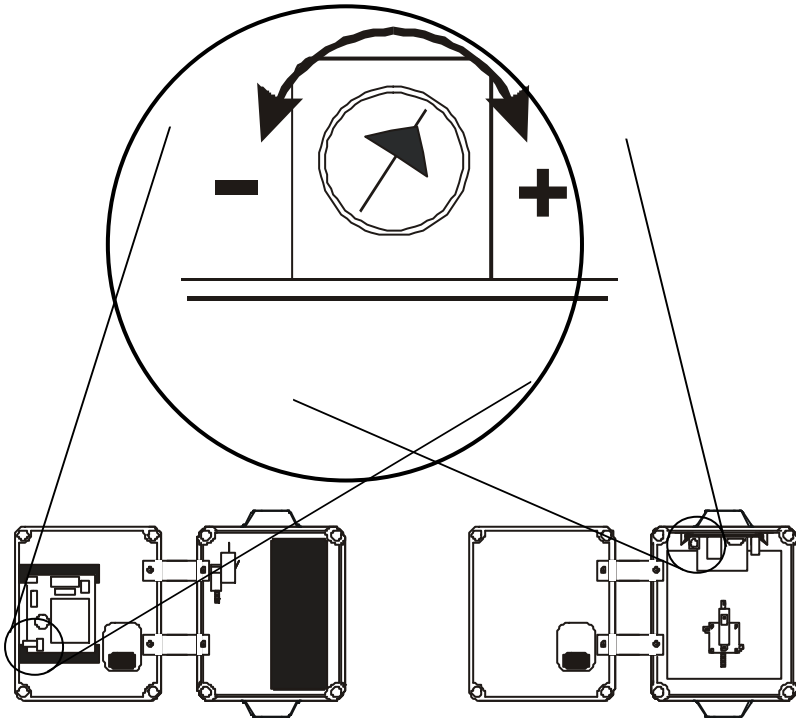

Specification

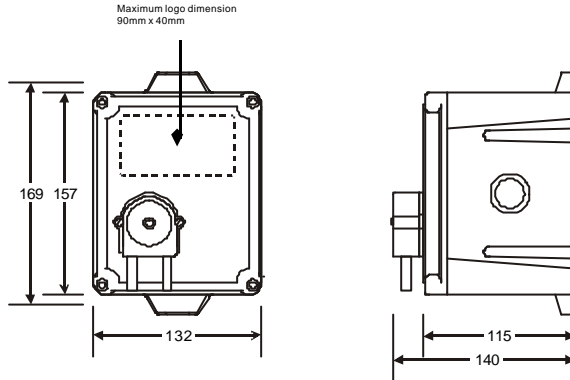

Enclosure:

IP65M ABS

Pump:

Silicone Tube

Mains = Max - 54ml, Min - 1 ml

Battery = Max - 25ml, Min - 1 ml

Supply:

Mains - ~230V 50/60Hz

Battery - 12V DC

Fusing:

Mains - T400mA

Battery - T1A

Motor:

Mains - 18V DC

Battery - 12V DC

Approvals:

EMC 89/336/EEC - EN50081-1:EN50082-1

LVD 72/23/EEC - EN60335-1

CAUTION: It is the responsibility of the user to ensure that the peristaltic tubes are compatible with the intended products.

HEAD OFFICE

Brightwell Dispensers Ltd
Brightwell Industrial Estate
Norton Road
Newhaven
BN9 0JF
UK

All Orders: +44 (0)1273 513566
Sales: +44 (0)1273 511300
Fax: +44 (0)1273 516134

BENELUX & GERMAN OFFICE

Brightwell Dispensers Ltd
Lonneker Steumke 21
Enschede
NL-7524 DN
The Netherlands

Sales: +31 (0)53 4344018
Fax: +31 (0)53 4344022

www.brightwell.co.uk
brightmail@brightwell.co.uk