

BRIGHTWELL

REVOLUTIONARY DISPENSING SOLUTIONS

Laundry Systems

BrightLogic

Instruction Manual

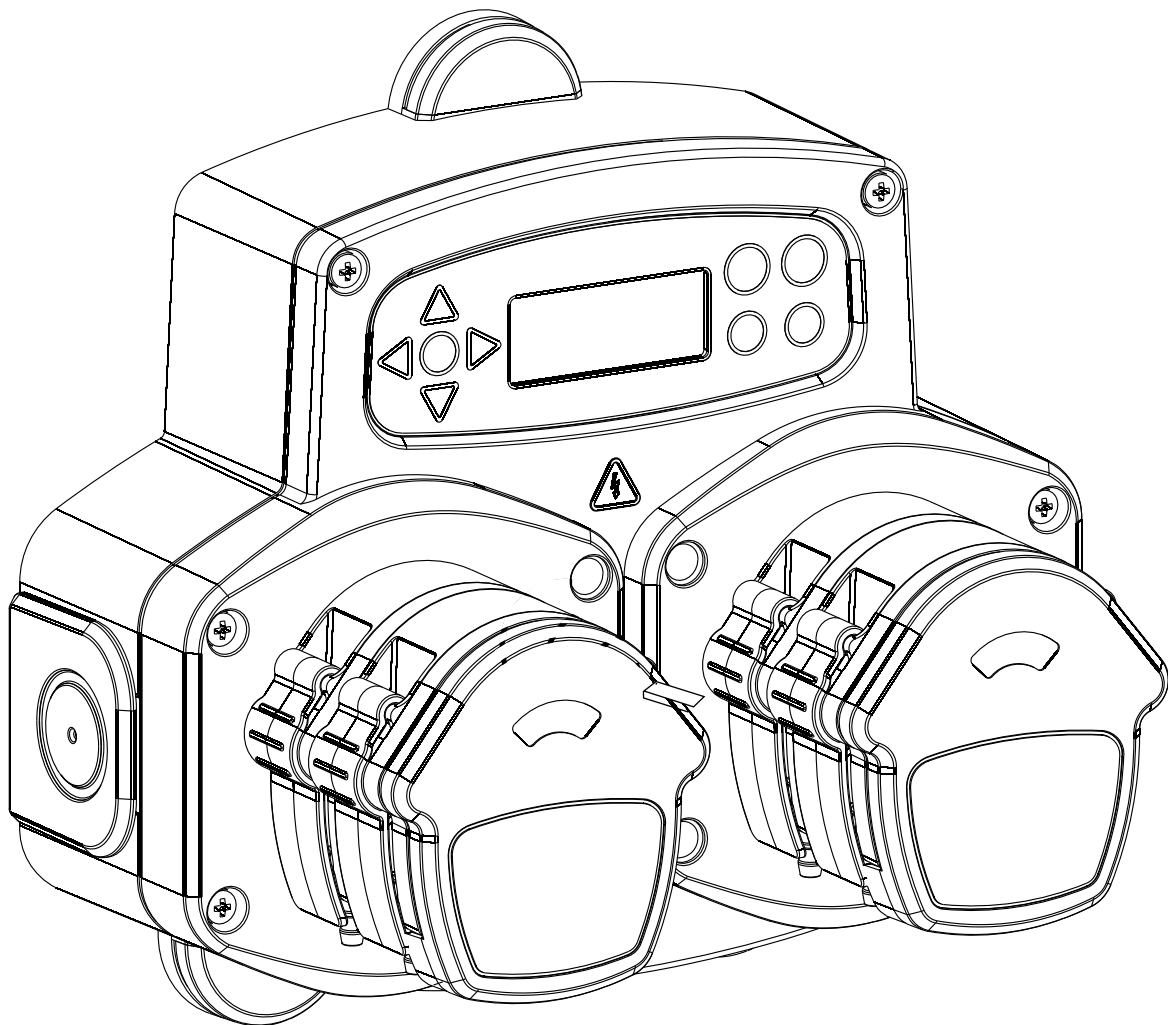

<i>Operation</i>	3	<i>Programming:</i>	
<i>Safety Precautions</i>	4	<i>From a Laptop</i>	13
<i>Unit Layout:</i>		<i>Controls</i>	14
<i>External</i>	5	<i>Key to Instructions</i>	14
<i>Keypad & Screen</i>	5	<i>Language Selection</i>	14
<i>Board Position</i>	6	<i>Entering Program Mode</i>	15
<i>Installation:</i>		<i>Signal Acceptance Time</i>	15
<i>Mounting</i>	7 - 8	<i>Assigning Manifolds</i>	16
<i>Wiring 1</i>	9	<i>Flush Valve Mode</i>	16
<i>Wiring 2</i>	10	<i>Safety Stop mode</i>	17
<i>Formula Select:</i>		<i>Flush Valve Time</i>	18
<i>Operation</i>	11	<i>Setting Pump Speed</i>	18
<i>Safety Precautions</i>	11	<i>Setting Pump Flowrate</i>	19
<i>Layout</i>	11	<i>Selecting Input</i>	20
<i>Installation</i>	12	<i>Pulse Count</i>	21
<i>Pump Prime / Stop Mode</i>	12	<i>Enabling Pumps</i>	22
		<i>Pump Delay Time</i>	22
		<i>Dosage</i>	23
		<i>Run Time</i>	23
		<i>Reset Condition</i>	24
		<i>Reset Delay</i>	24

Programming (cont):

Resetting program options.....25

Auto Formula Select Mode.....26 - 27

Summary Screen.....27

Save Settings/Exit Program.....28

Creating Additional Programs.....28

Copying an Existing Program.....29

Deleting an Existing Program.....29

Cycle Counters.....30

Accessing Relay Mode.....31

Relay Mode.....32

Accessing Levels Mode.....33

Wireless USB settings.....34

Priming the Pumps.....34

Stopping the Pumps.....35

View Mode.....35

Pulse Test.....36

Software/Serial Number.....36

Test Mode.....37

Glossary.....38

Specification:

L Unit.....40

L/H Unit.....40

Formula Select.....41

Manufacturer Contact Details.....44

The BrightLogic Computer Software, which enables direct programming of any BrightLogic unit from a laptop, is available on request.

Email:
brightmail@brightwell.co.uk

Or go to our website:
www.brightwell.co.uk

The BrightLogic Laundry Units, are automatic dosing systems design for use with commercial washing machines. The units are intended for indoor, fixed installation only. The means of disconnection must be incorporated in the fixed wiring, with an air gap of at least 3mm in each pole.

The pumps are initiated by applying signals of between 90V and 240V AC or DC across the corresponding inputs of the A and B rails on the powerboard.

Note: signals of between 12V and 240V AC or DC can be accepted by removing resistor packs RP1 to RP4 see page 9 or 11.

Features include:

- User programmable signal acceptance time (see page 15)

- Data management

- Auto Formula select modes

- 3 flush valve outputs, which operate with user assignable pumps (see page 16)

- User programmable flush valve times (see page 26)

- Each pump can be assigned a single input, multiple inputs or all inputs (see page 28)

- Each pump has user selectable:

 - Speed/Flowrate (see pages 26 and 27)

 - Delay Time (see page 30)

 - Run Time/Chemical Dosage (see page 32)

The unit has three operating modes: -

- Standard

- Relay

- Levels

Standard Mode

Used with standard host machine.

The relevant pump will operate when a signal is present for the duration of the signal acceptance time and is equal to the programmed pulse setting.

The pump will then remain static for the period of the delay time, before operating at the programmed speed, for the programmed run time or chemical dosage.

The pump will not operate again until the unit has reset. The unit can be selected to reset after the operation of the final pump (eg. pump 4 of a 4 pump unit) or on a signal to input 10.

Relay Mode

Used with a computer controlled host machine.

The pumps will operate for the duration that a signal is present across the corresponding inputs. Input 1 operates pump 1, input 2 /pump 2, etc. The data management flush valve and machine interrupt features will remain.

Levels Mode

Used with a standard host machine. The relevant pump will operate when a signal is present for the duration of the

signal acceptance time and is equal to the programmed pulse setting. The pump will then remain static for the period

of the delay time, before operating at the programmed speed, for the programmed run time or chemical dosage.

The pumps have three individual levels in which dosing can take place in each wash program and activated by the corresponding inputs. Input 1 operates pump 1, input 2/pump 2, etc.

Important Safety Instructions

Please read the following precautions carefully before using this equipment.

This unit contains high voltage components which, may expose you the risk of electric shock.

Do not open the enclosure without isolating the signal and supply sources. Ensure that these sources have been isolated for at least 5 minutes before entering the enclosure.

Means for disconnection must be incorporated in accordance with the wiring rules.

Do not mount the unit to unstable, irregular or non-vertical surfaces.

Do not place heavy objects on top of the unit.

Do not attempt to place items (such as screwdrivers) into the moving parts of the pumphead.

Do not power the unit outside of the values stated on the rating label.

Do not use damaged or frayed cables.

Do not dismantle or modify this equipment.

Do not allow the appliance to be used by persons (including children) with reduced physical, sensory or mental capabilities, or lack of experience and knowledge, unless they have been given supervision or instruction.

Do not allow children being supervised to play with the appliance.

Do not use appliance if the supply cord is damaged. This must be replaced by the manufacturer, its service agent or similar qualified persons in order to avoid a hazard.

Always ensure that care is taken when handling chemicals.

WARNING

This is a Class A product. In a domestic environment this product may cause radio interference in which case the user may be required to take adequate measures.

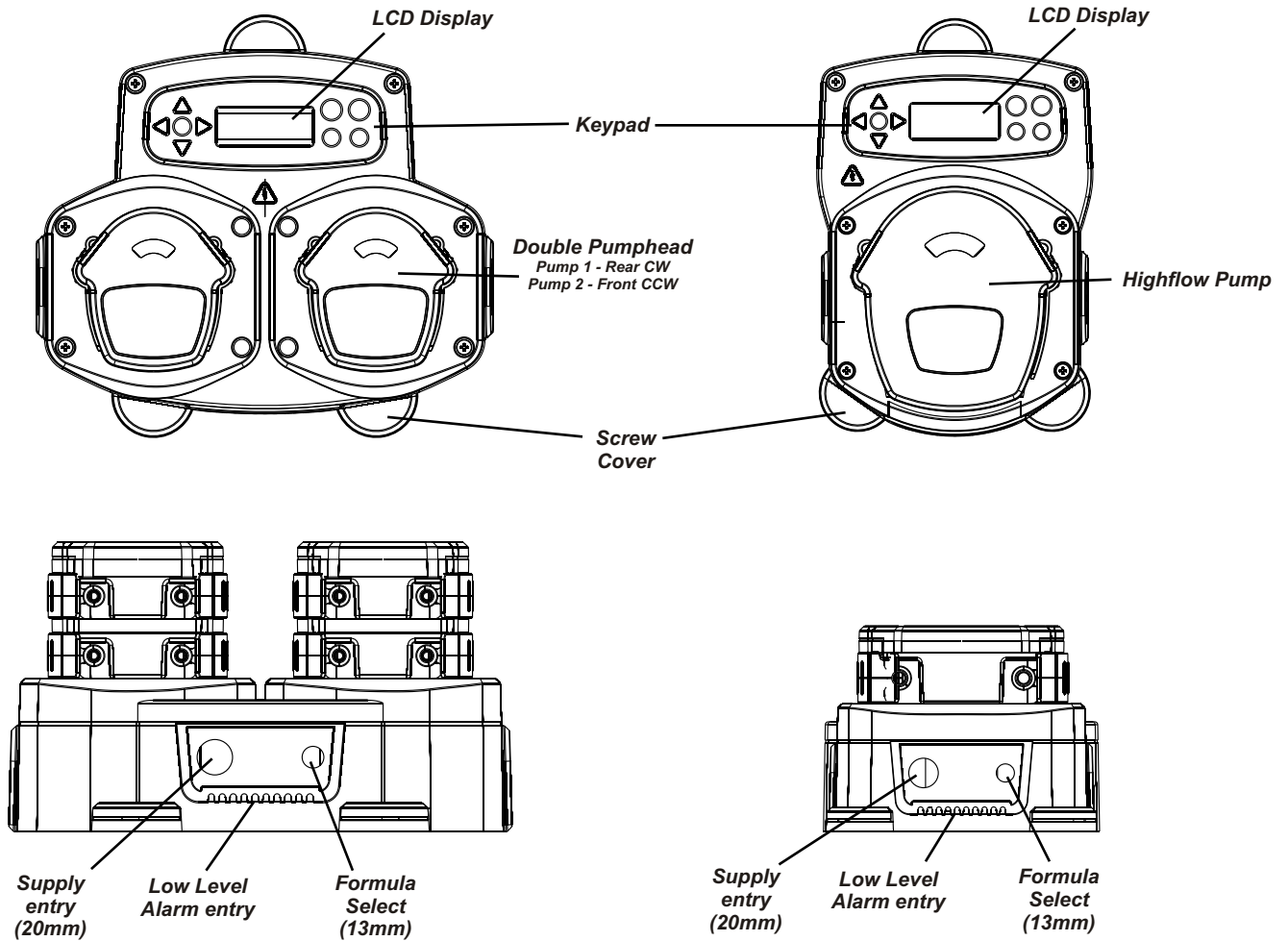

Note: Suitable cable glands and cable size should be used to ensure that the units IP rating is kept.

UNIT LAYOUT - KEYPAD & SCREEN

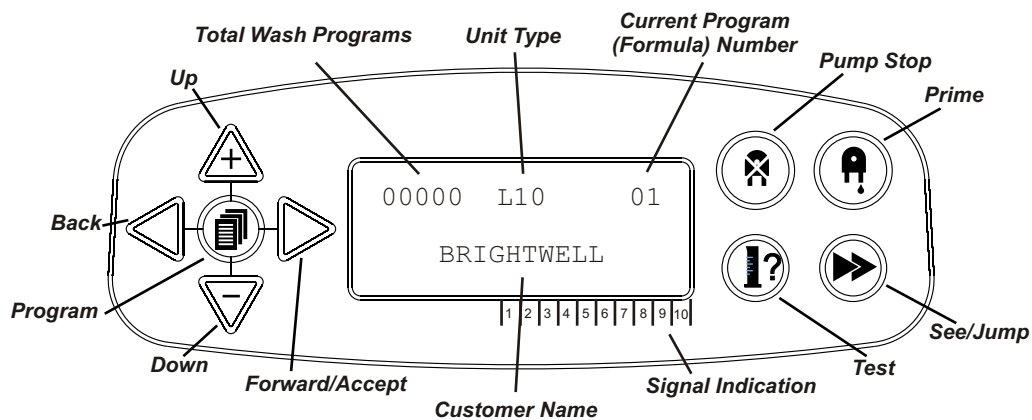

UNIT LAYOUT - MICROBOARD

Used on:
L1-10
L1-10/H

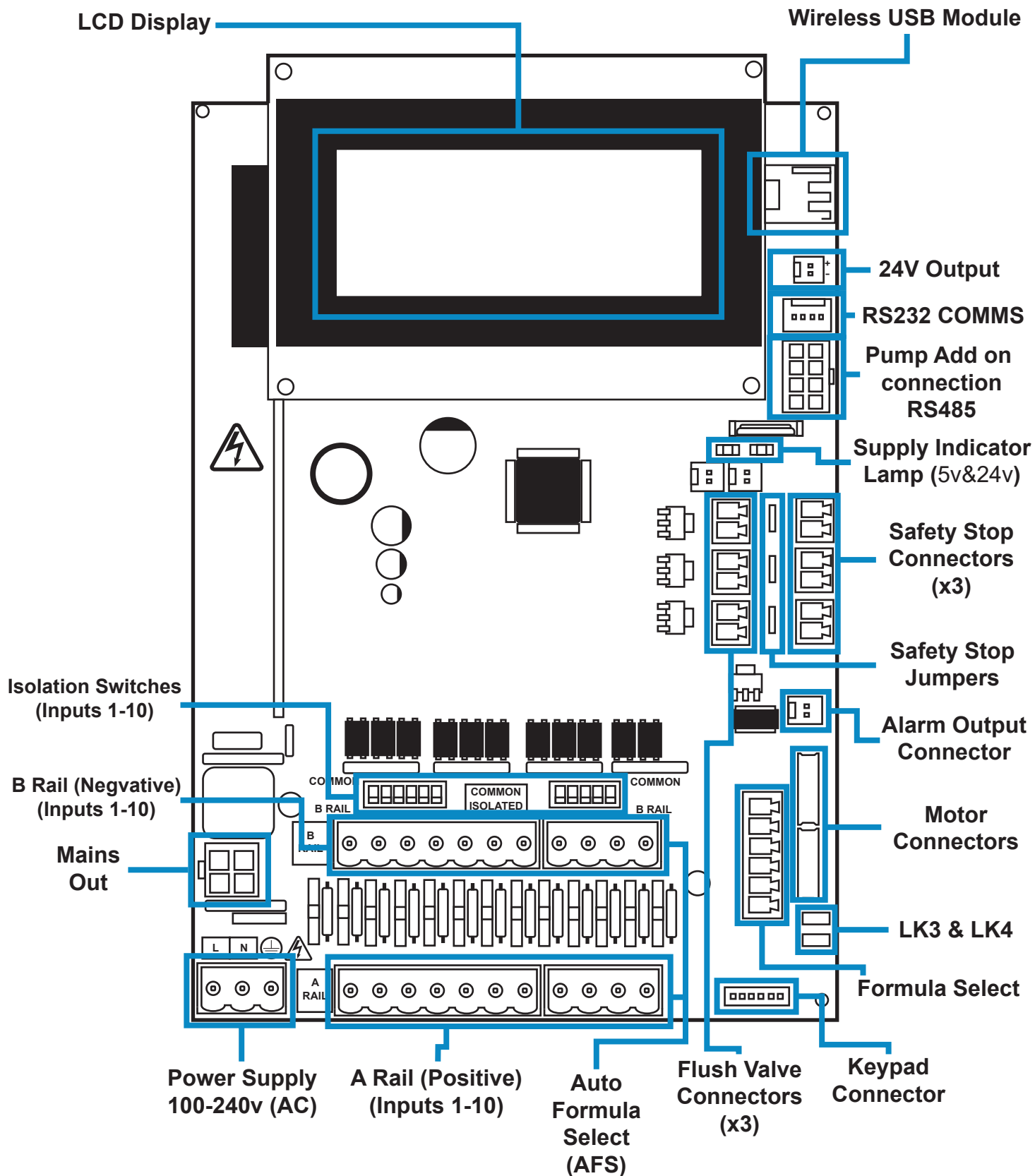

Fix the unit to a vertical wall using the screws provided.

Ensure that the unit is level and positioned no more than 2 metres above the base of the product, which is to be dispensed.

Important Notes.

Maximum recommended suction and delivery tubes - 2 metres

Minimum tube size - 8x11mm

Screw pitch / Drilling diagram - on next page



Ø 6mm



x 3 per Enclosure

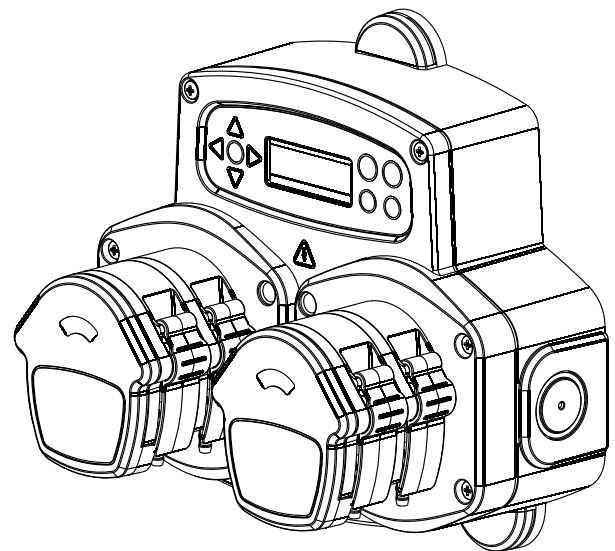

**MAXIMUM
2 Metres**

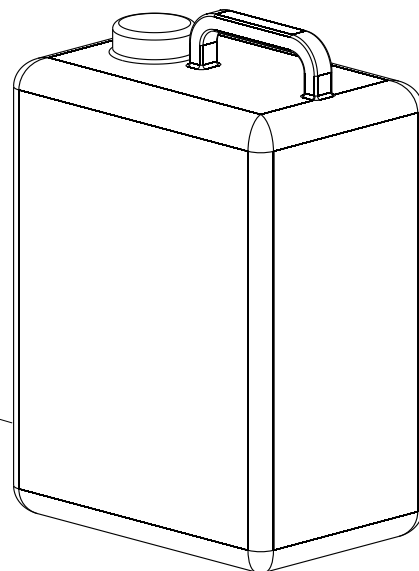

Drill mounting holes to the following pitch.

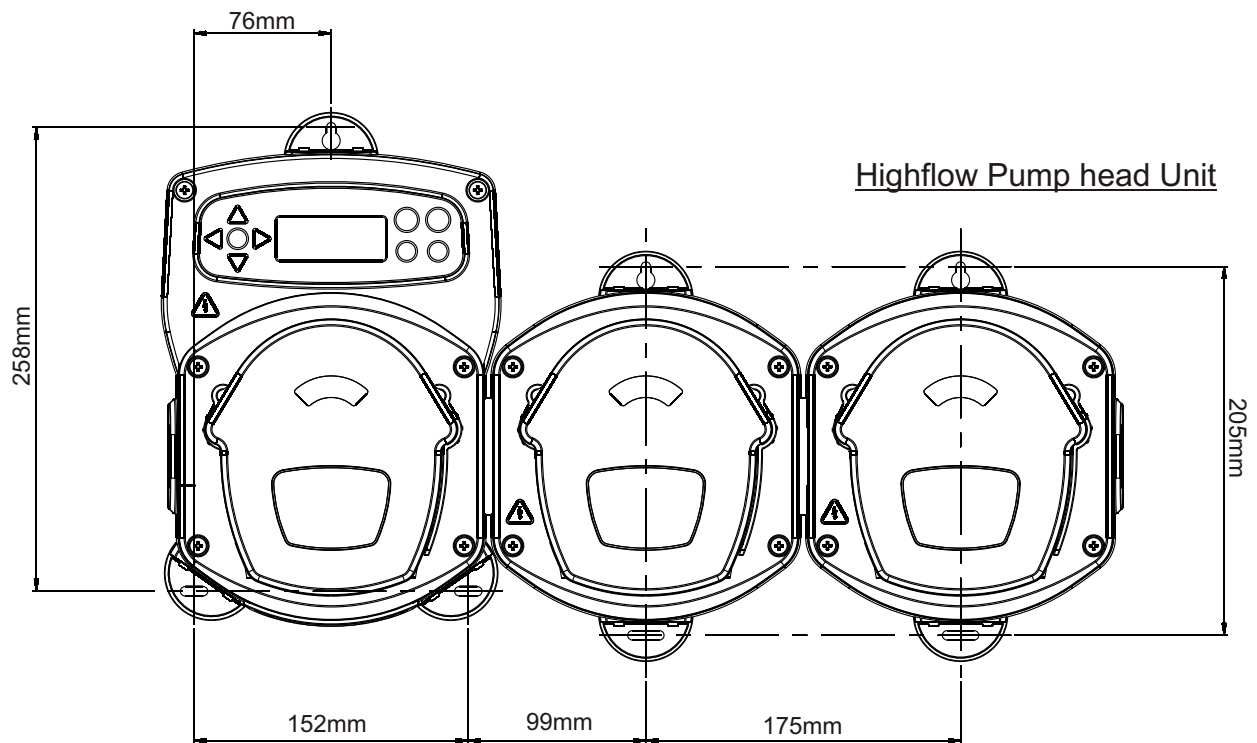
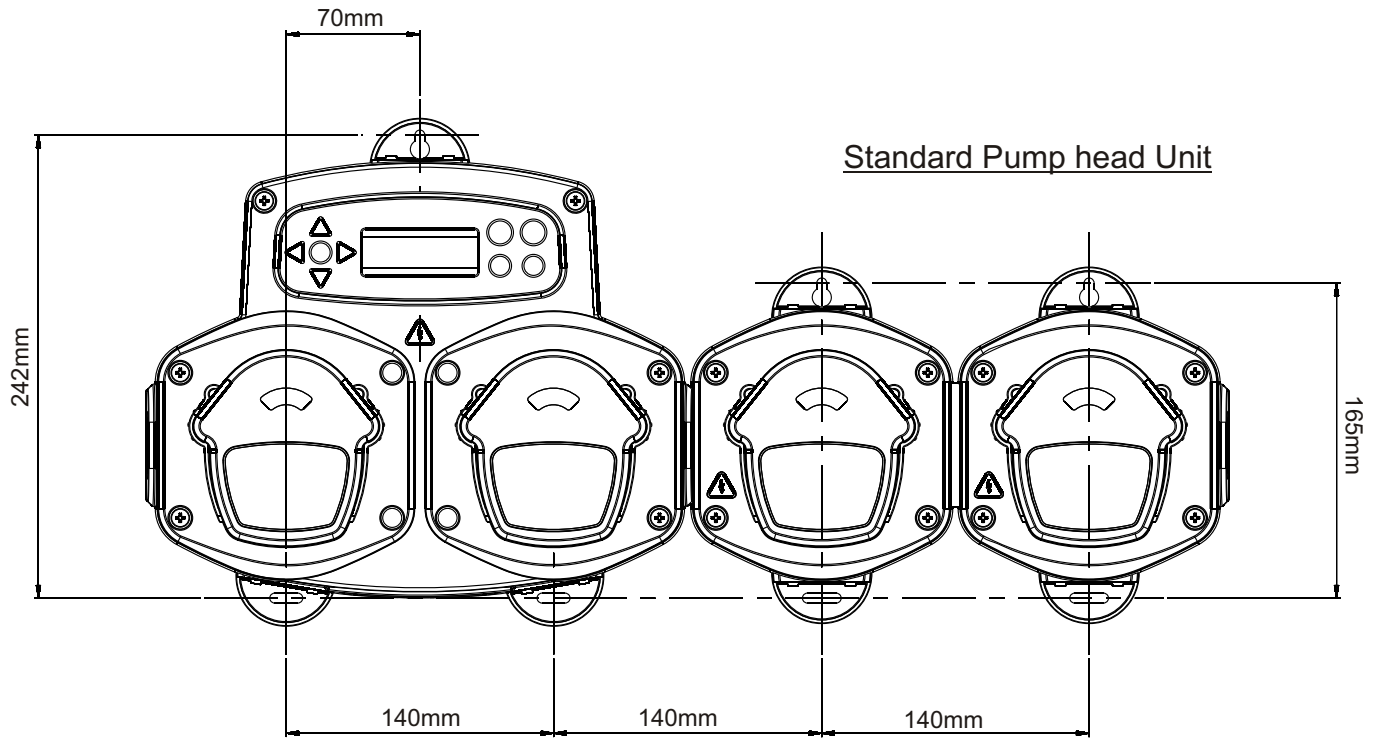

In most cases, the interface board or solenoids in the host machine will have a common (i.e. their negative terminals are all linked by a common wire).

The Switches LK10 - LK19 can be left switched to common (up position), and the single (common) wire taken to the B rail.

Note:

If a signal is applied to Input 2 before Input 1 then the unit will assume that a Pre-wash is not occurring and will ignore subsequent signals to Input 1 until the unit has reset.

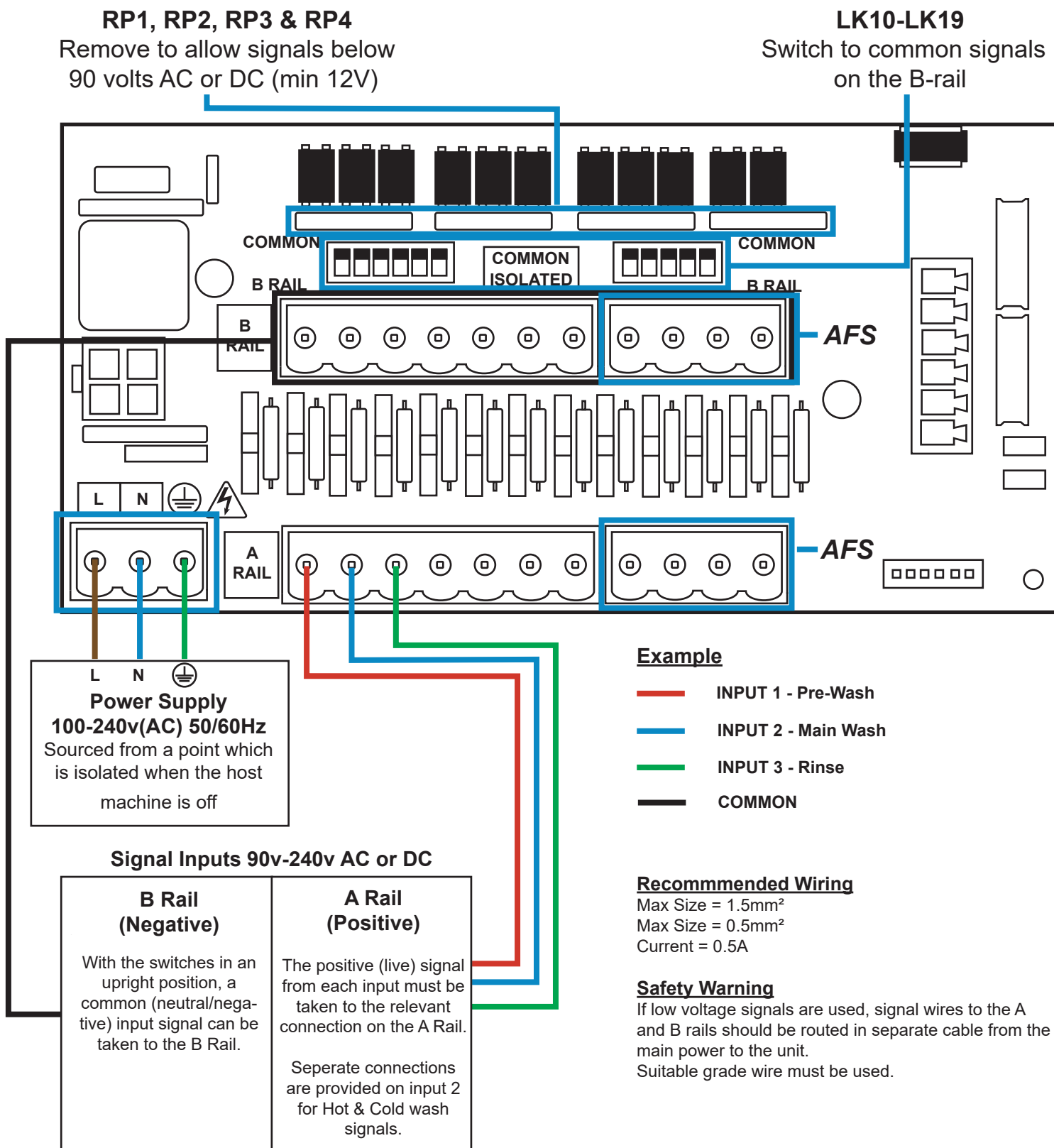

In some cases, the interface board or solenoids in the host machine are **not** common. **For example:** The softener solenoid on some Miele machines is not linked via a common wire to the other solenoids.

If this is the case, the signal **must** be isolated from the common B rail on the Board. This is done by Switching the appropriate switch (LK10 to Lk19 to isolated, ie. Downward position). If in doubt switch the appropriate switch for each incoming signal source.

FAILURE TO SWITCH THE APPROPRIATE SWITCH WOULD RESULT IN UNIT FAILURE.

DO NOT ATTEMPT TO SWITCH THE SWITCHES WHEN THE POWER IS ON.

Note:

If a signal is applied to Input 2 before Input 1 then the unit will assume that a Pre-wash is not occurring and will ignore subsequent signals to Input 1 until the unit has reset.

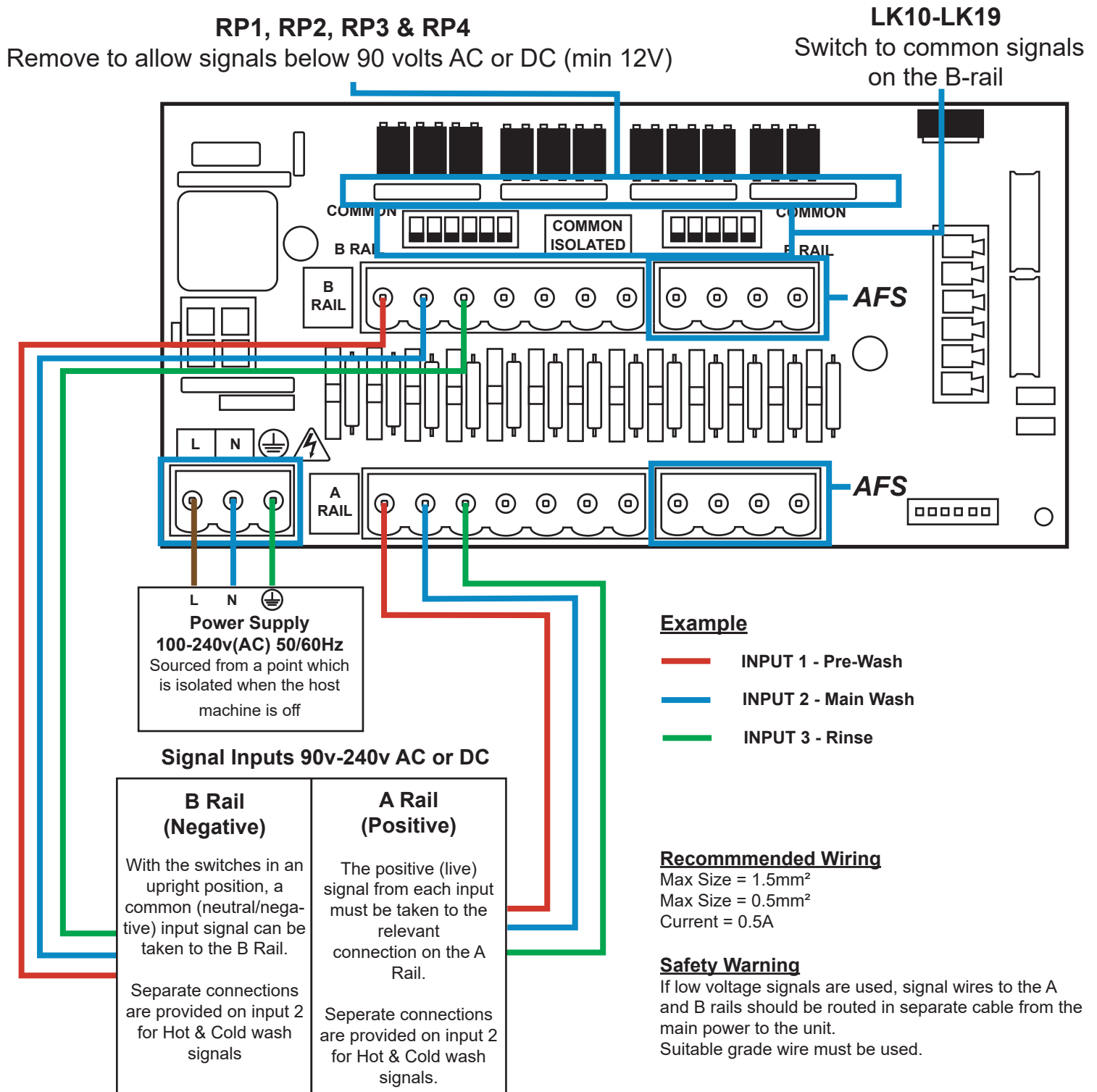

The BrightLogic laundry Formula Select module (optional) allows remote selection of up to 20 different wash programs, program names can be displayed by uploading via the computer program

The Formula Select module can also be used to prime and stop the pumps.

The desired program must be selected, using the UP and DOWN keys on the module and pressing enter, before beginning the wash cycle.

Resetting options

There are four options available to reset the formula select:

Reset Formula to Program 01 - (default setting)

Reset Formula to Program 00 - (blank program)

Reset Formula to Program 02 - (set to any program number)

Reset Formula to Previous program - (resets to the previous program)

See "Resetting options" section
(Page 25)

The unit can be manually reset by pressing the up and down keys together for 2 seconds.

With out a Formula Select module

If there is no formula select installed then the programs can still be selected from the unit itself.

Press the **PROGRAM** button to toggle through the programs that have been programmed.

FORMULA SELECT - SAFETY PRECAUTIONS

Important Safety Instructions

Please read the following precautions carefully before using this equipment.

Do not attempt to fit the module without first isolating the signal and supply sources from the host unit.

Do not use damaged or frayed cables.

Do not dismantle or modify this equipment.

FORMULA SELECT - LAYOUT

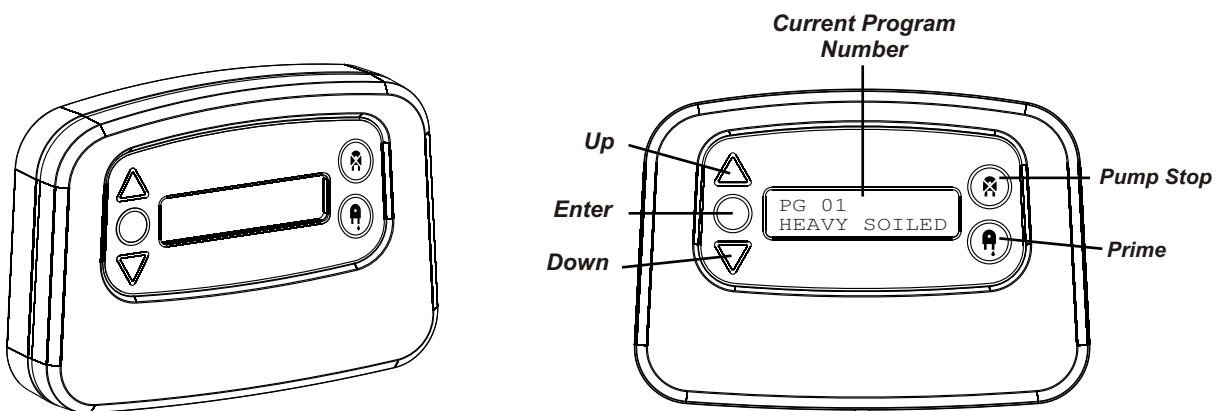

Fit the module to a suitable surface, in an accessible area, using the self-adhesive Velcro provided.

Before fitting, please ensure that the power to the unit has been isolated.

Open the lid of the main enclosure.

Pass the cable through the gland situated on the bottom of the unit and run it to the vicinity of the Formula Select connection socket on the board.

Note:

Screened cable should be used.

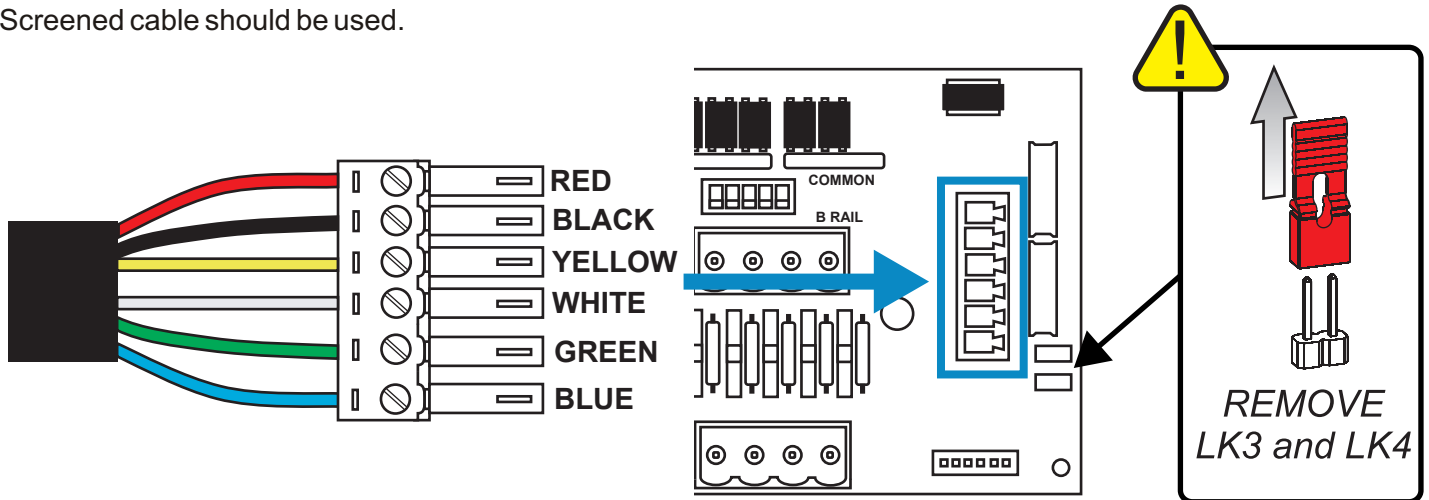

Fit the green connector with the coloured wires in the order shown above. Plug the connector into the correct socket and tighten the gland to grip the cable.

ENSURE YOU REMOVE links LK3 & LK4.

PRIMING / STOPPING PUMPS - FROM THE FORMULA SELECT

PRIME MODE

To Prime the Pumps from the Formula Select module, press the **PRIME** key for 2 seconds and the Module screen will display PRIME MODE.

Use the **UP** and **DOWN** keys to select the required pump number.

Press and hold the **ENTER** key to prime the corresponding pump.

Press the **PRIME** key to return to normal screen or it will return if no keys are pressed for 5 seconds.

PUMP STOP MODE

To Stop the Pumps from the formula select module, press the **PUMP STOP** key for 2 seconds and the Module screen will display PUMP STOP MODE.

Use the **UP** and **DOWN** keys to select the required pump number.

Press the **ENTER** key to change the state from ON to OFF or vice versa.

Press the **PUMP STOP** key to return to normal screen or it will return if no keys are pressed for 5 seconds.

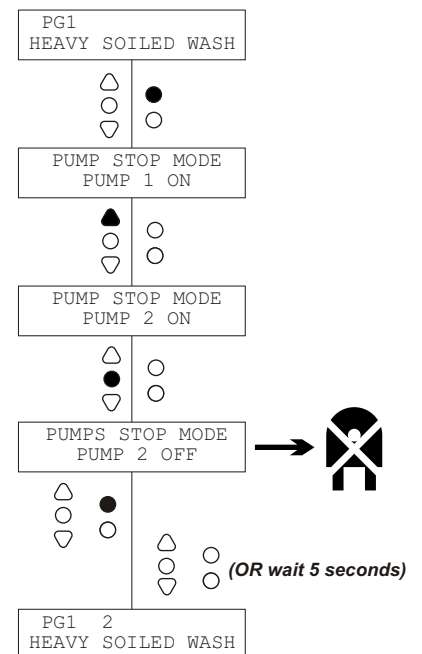
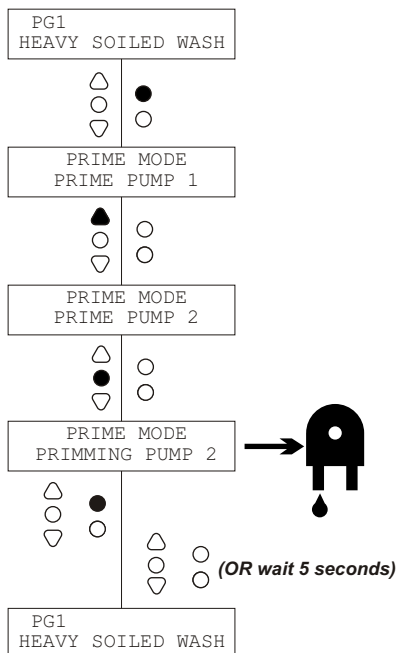

All of the programming procedures in this booklet, can be performed on a computer before installation using the BrightLogic computer software.

In this way, directories of parameters for common installations and all unit types can be created and saved.

Data (such as Program parameters, Chemical names, Flowrates, Run times and Cycle times) can be read from the unit and used to generate Excel spreadsheets, to which the users own comments can be added.

These spreadsheets can be used to perform simple monitoring, testing and diagnosis of the system.

The BrightLogic computer software is available for use with all BrightLogic Laundry Systems.

For full instruction on the use of the computer software, see the separate instruction booklet (B988).

The BrightLogic computer software is available for download from our website (www.brightwell.co.uk).

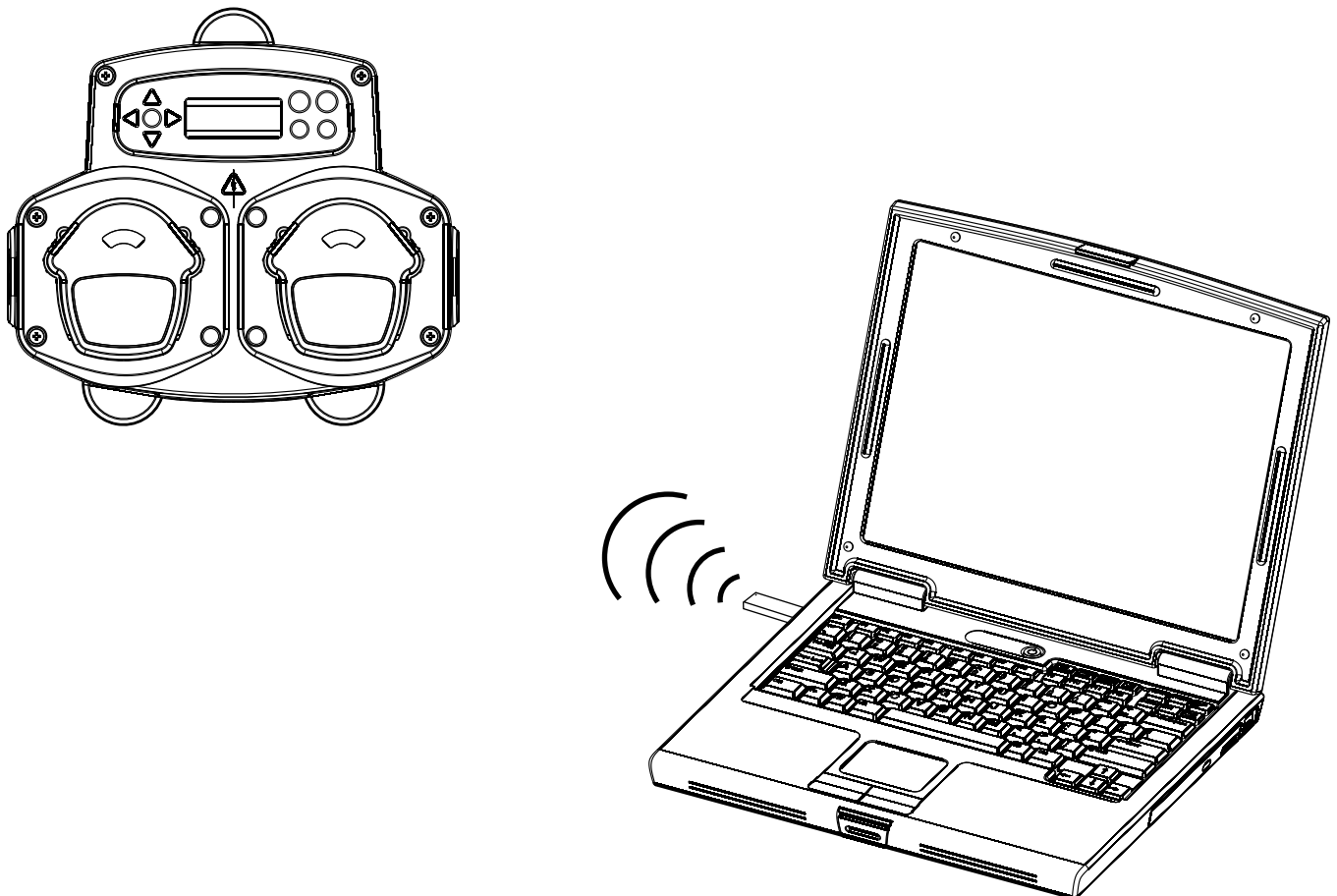

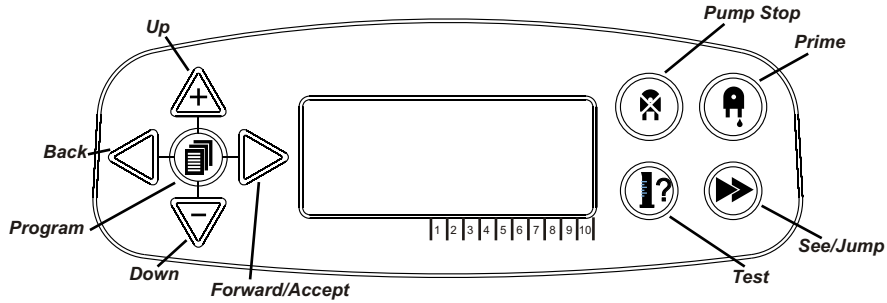

PROGRAMMING - KEY TO INSTRUCTIONS

Throughout the instructions:

- If a button or buttons are shown in black then they must be pressed to progress to the next stage. (If two buttons are shown, they must be pressed together)
- If buttons are shown in grey, they are used individually to achieve the desired result. (ie. Either/or)

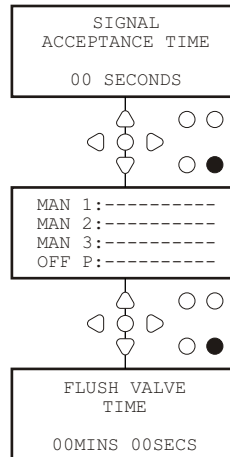

Throughout the instructions, there are several screens which are highlighted **Bold**.

From any point within the program, the user can transition to the next **Bold** screen via the **SEE/JUMP** button.

PROGRAMMING - LANGUAGE SELECTION

It is possible to select the displayed language as English, French, German, Spanish, Dutch, Czech, Polish, American Italian or Portuguese.

From the default screen, press and hold the **TEST** key for 2 seconds. The access code screen will then be displayed. Enter the correct four-digit access code using the **UP** and **DOWN** keys to select a number and the **FWD/ACCEPT** key to move on (see page 15).

Use the **UP** and **DOWN** keys to scroll through the language options. Press the **FWD/ACCEPT** key to select the displayed

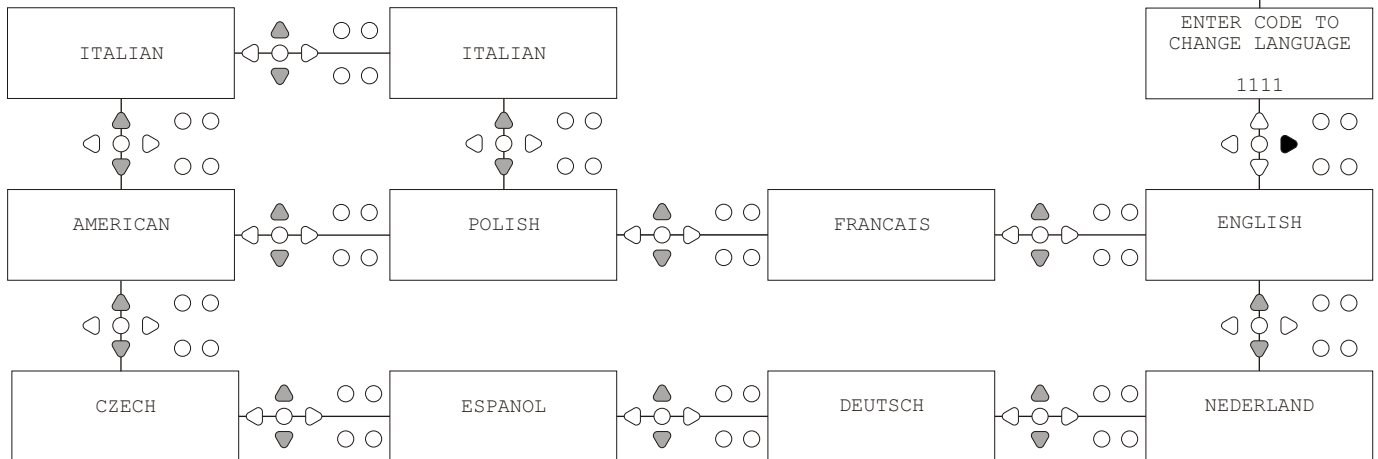
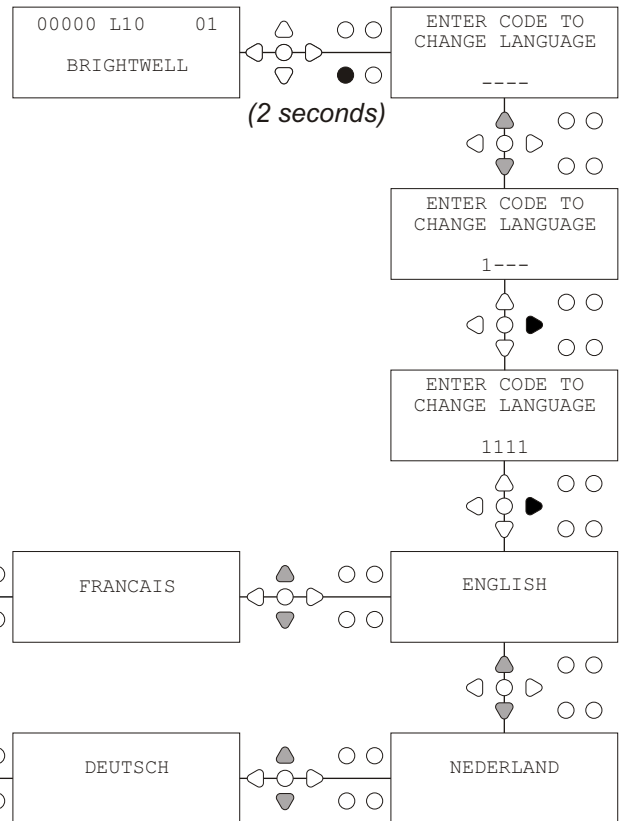

From the default screen, press the **FWD/ACCEPT** key.

Enter the correct four-digit access code using the **UP** and **DOWN** keys to select a number and the **FWD/ACCEPT** key to move on/confirm.

The unit will then give the option of editing the:

Settings (see below)

Or

Wireless USB settings (see page 33)

Or

Cycle Counters (see page 30)

Or

Date and Time Settings

Press **UP** and **DOWN** to select the required option, and **FWD/ACCEPT** to accept your choice and move on the next screen.

Note:

While in PROGRAMMING MODE the unit will not run and will not accept input signals from the host machine.

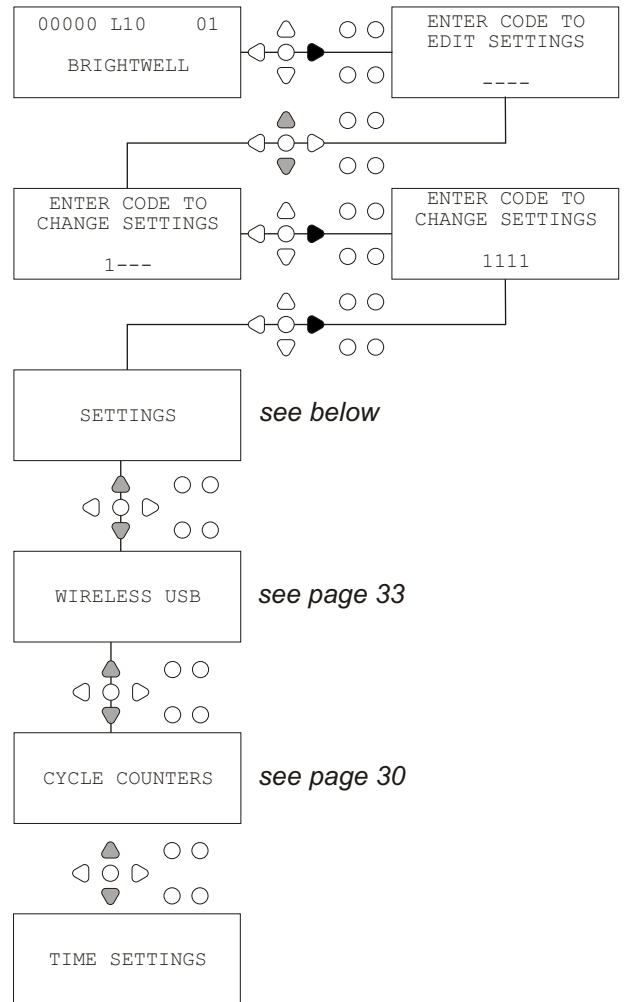

PROGRAMMING - SIGNAL ACCEPTANCE TIME

From the SETTINGS screen, press the **FWD/ACCEPT** key to move to the SIGNALACCEPTANCE screen.

Usually set to 1 second, the signal acceptance time is the time that a signal has to remain across an input, before it is acknowledged. Once set, this time will apply to all inputs and all programs.

Setting:

Set the Signal Acceptance Time (00 - 99 Secs) using the **UP** and **DOWN** keys. Press **FWD/ACCEPT** to accept your choice and move on to the ASSIGNING MANIFOLD screen.

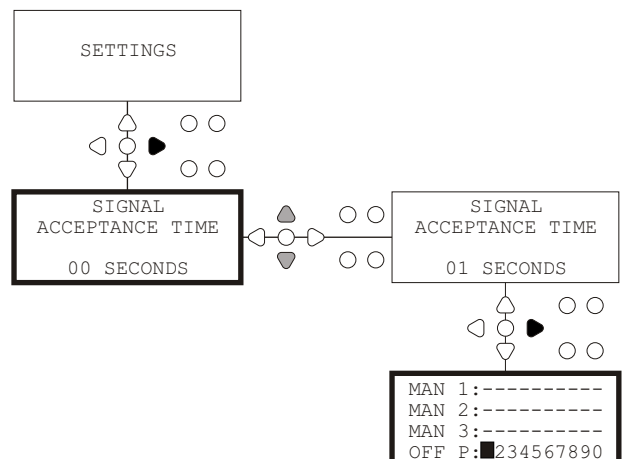

Important

All settings shown in this instruction manual are for illustration/example only.

The settings, which you use must be derived from your own knowledge and experience, combined with experimentation and the requirements of the installation.

Once the SIGNAL ACCEPTANCE TIME has been set, press the **FWD/ACCEPT** key to move to the ASSIGNING MANIFOLD screen.

The BrightLogic software allows the user to have a maximum of three manifolds (flush valves). By assigning each pump to a specific manifold, the flush valve of that manifold will open when the pump runs.

Use the **UP** and **DOWN** keys to set each pumps cursor to the line of the required manifold. Press **FWD/ACCEPT** to confirm and move on to the next pump.

Once all of the pumps have been assigned to the correct manifolds (or OFF), press the **FWD/ACCEPT** key to move onto the FLUSH VALVE TIME screen.

Note:
If all the pumps are set to OFF, the display will move to the PUMP SPEED screen.

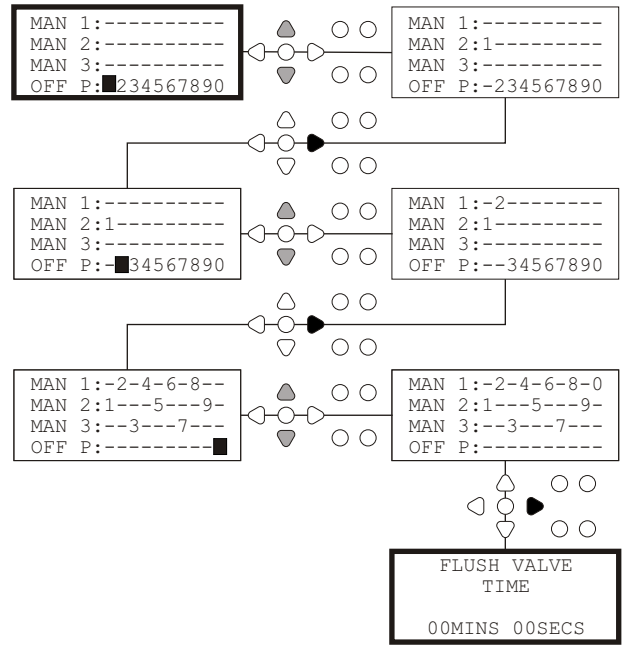

PROGRAMMING - FLUSH VALVE MODE

The flush valve has two operational modes:

DURING & AFTER:

The flush valve will open 1 second before the pump starts to run, the valve will stay open while the pump is running. Once the pump has stopped, the flush valve will remain open for the duration of the programmed time (see page 18).

AFTER ONLY:

The flush valve will only open once the pump has stopped. The valve will then remain open for the duration of the programmed time (see page 18).

Setting:

From the FLUSH VALVE TIME screen, press the **PRIME** key to access the FLUSH VALVE MODE screen.

Use the **UP** and **DOWN** keys to toggle between the two options. Once the desired option is displayed, press **FWD/ACCEPT** to confirm your selection and move back to the FLUSH VALVE TIME screen.

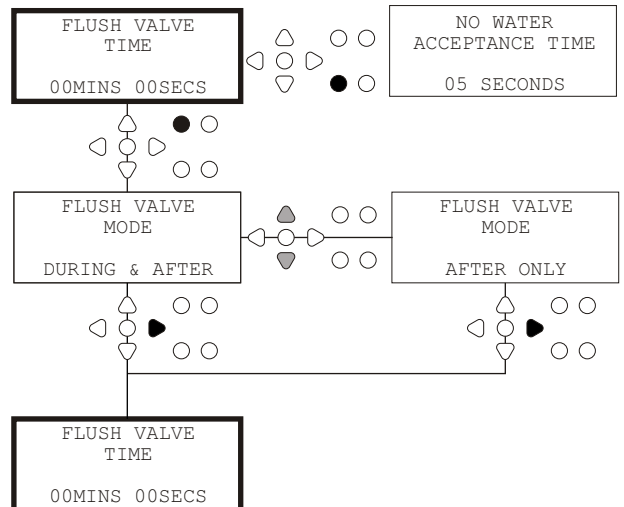

There are two possible safety stop switches for the manifold system. As they work differently, they have different settings within the programming.

It is very important that you ensure the correct option is selected!

The device connections for the Safety Stop input are on the main board, and are activated by the removal of link LK5 - LK7 (see page 6).

Setting:

From the FLUSH VALVE TIME screen, press the **PUMP STOP** button to access the SAFETY STOP MODE screen.

Use the **UP** and **DOWN** buttons to toggle between the two options. Once the desired option is displayed, press **FWD/ACCEPT** to confirm your selection and move back to the FLUSH VALVE TIME screen.

FLOW SWITCH:

If there is no water present in the manifold system and the flush valve is on. Then the screen will display NO WATER PRESENT & the buzzer output will sound (if connected).

Once the switch has been activated, the Brightlogic unit will not function again, until the water has been restored and the **PROGRAM** button has been pressed for 1 second.

PRESSURE SWITCH:

If there is no water present in the manifold system, the screen will display NO WATER PRESENT & the buzzer output will sound (if connected).

Once the switch has been activated, the Brightlogic unit will not function again, until the water has been restored.

The switch will activate regardless of the position of the solenoid.

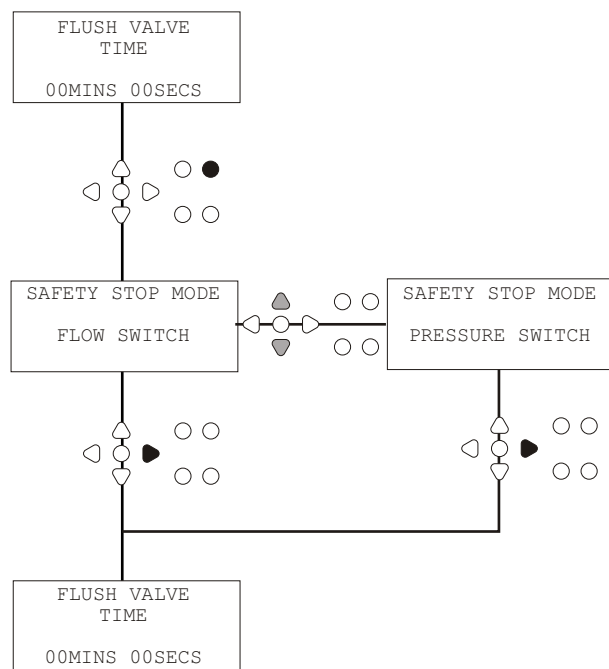

NO WATER PRESENT



The buzzer can be snoozed for a 30 minute period, by pressing the **PROGRAM** button.

◀ ● ▶ = zzz



To overcome problems such as air bubbles or other equipment connected to the water supply, both of the switches feature a 1 second signal acceptance time.

The Flush Valve Time, is the time for which the flush valve will open, after the assigned pump has run.

Set the flush valve time (00 - 99 Mins) using the **UP** and **DOWN** keys.

Press **FWD/ACCEPT** to select the displayed time and move to the PUMP SPEED screen.

Note:

Once set, this time will apply to ALL Flush Valves.

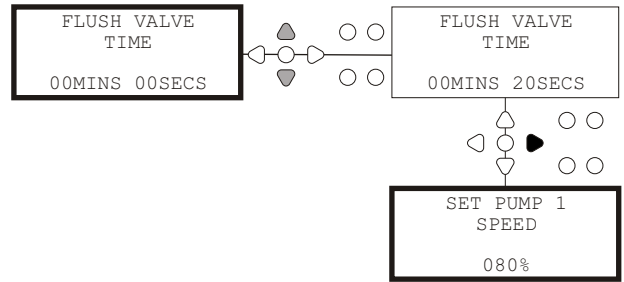

PROGRAMMING - PUMP RUN SPEED

From the FLUSH VALVE TIME screen (or the ASSIGNING MANIFOLD screen if flush valves are not needed), press the **FWD/ACCEPT** key to move to the PUMP SPEED/FLOWRATE screen.

The BrightLogic software allows the user to program each pump with a Flowrate (see page 19) and/or a Pump Speed.

PUMP SPEED:

The user can set the speed of each individual pump (30% - 100% of full speed, in 5% increments).

This can be used to reduce the strain on the pumps when they are used with thick products.

Setting:

Use the **UP** and **DOWN** keys to select the desired speed for the selected pump.

Press **FWD/ACCEPT** key to confirm your selection and move on to the next pump.

Once all of the pump speeds/flowrates have been set, press the **SEE/JUMP** key to move onto the PROGRAM SETTINGS screen.

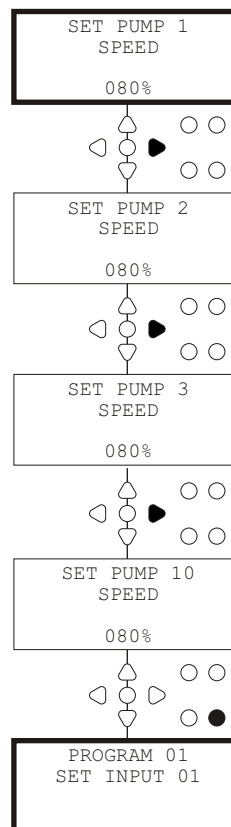

From the FLUSH VALVE TIME screen (or the ASSIGNING MANIFOLD screen if flush valves are not needed), press the **FWD/ACCEPT** key to move to the PUMP SPEED/FLOWRATE screen.

The BrightLogic software allows the user to program each pump with a Flowrate and/or a Pump Speed (see page 18).

FLOWRATE:

This is useful as it enables the user to program the unit with a specific dosage instead of a run time. In turn, the unit will be able to supply accurate information on the volume of product dispensed by the unit, as well as cycles performed.

If a flow rate is being set, the pump speed will normally be left at its default setting (80%), unless the pump is being used with a thick product. In this case the pump speed can be reduced in order to ease the strain on the pump.

Setting:

While at the PUMP SPEED screen, press the **TEST** key. This will run the pump for 1 minute. During this time, the flowrate of the pump (volume dispensed in 1 min) can be measured.

Press the **PRIME** key to display the SET FLOWRATE screen.

Use the **UP**, **DOWN** and **FWD/ACCEPT** key to input the flowrate that you have just measured, and the date. Press **FWD/ACCEPT** key to confirm and move on to the next pump.

Once all of the pump speeds/flowrates have been set, press the **SEE/JUMP** key to move onto the PROGRAM SETTINGS screen.

Note:

If the flowrate is re-calibrated at a later date, the unit will automatically re-calculate and adjust the pump run time, so the correct dosage is dispensed over all 20 programs.

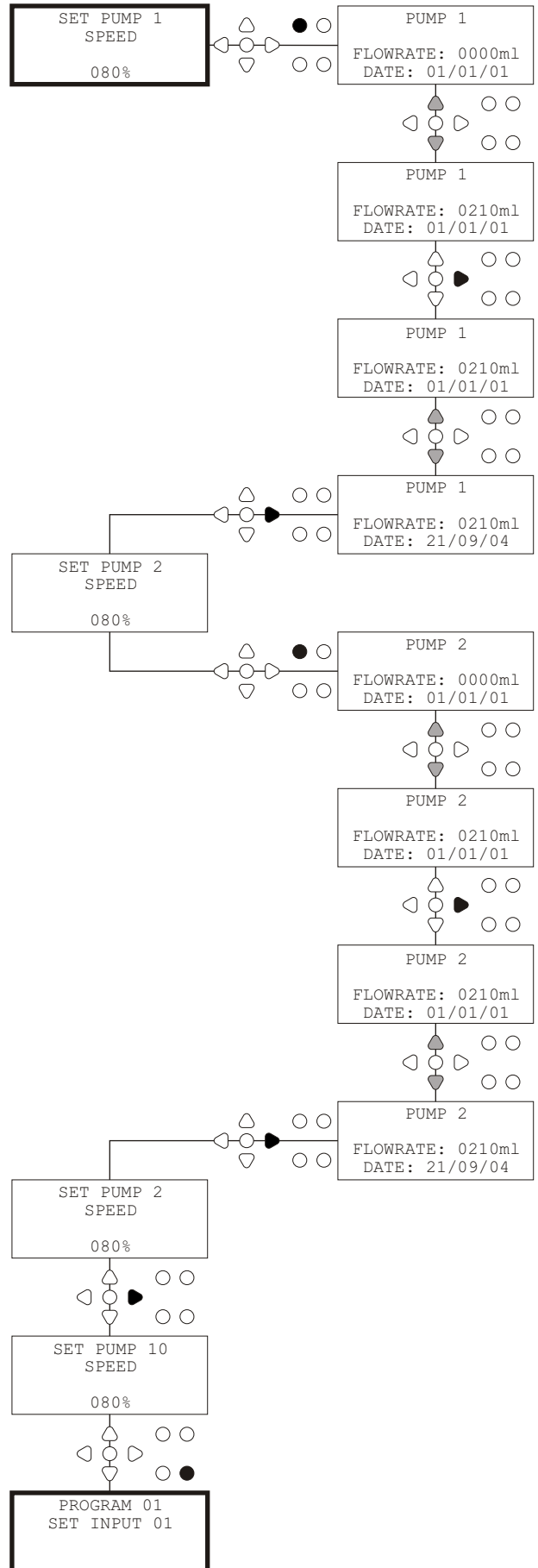

From the PUMP SPEED/FLOWRATE screen, press the **FWD/ACCEPT** key to move to the INPUT SELECTION screen.

From this screen the user can select which inputs they wish to assign to which pump.

BrightLogic units have a maximum of 10 inputs.

The inputs are situated on the A & B rails of the board. Each input can be assigned to an individual pump, multiple pumps or all pumps.

Example:

If the unit has been installed with signals from the host machine to inputs 01-04 on the powerboard, you will need to assign pumps to inputs 01-04.

Setting:

Using the **UP** and **DOWN** keys, select the first input which has a signal wired to it.

Press the **FWD/ACCEPT** key to move to the PULSE COUNT screen for the selected input.

Example:

In this example we want to program the unit to run pump 4 for 30seconds, when a signal is received on input 2.

Alternatively:

If needed, the INPUT SELECTION screen can also be used to access the pump settings for additional programs (formulas). BrightLogic units can have a maximum of 20 programs (see page 27).

Use the **PROGRAM** key to increment the program number at the top of the screen. The settings of this program can then be specified.

***For Levels mode - There are 3 level triggers per input**

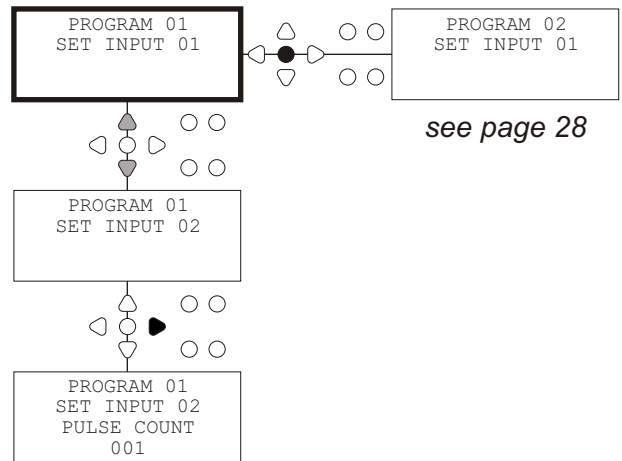

From the INPUT SELECTION screen, press the **FWD/ACCEPT** key to move to the PULSE COUNT screen.

The PULSE COUNT setting allows the user to select the number of signal pulses required by the displayed input, before the pump will run.

This is useful when (for example) a solenoid gives more than one signal during a cycle. In this case, if the unit were to run on every input signal, it would run several times during the wash cycle.

The unit can therefore be set to run on the first of the signals, the fourth, or any number up to 99, in order to avoid this multi-triggering.

Note:

In most circumstances the pulse count will be set to 01.

The unit can also be set to run on ALL pulses.

When set to ALL, the pump will run on every signal to the displayed input.

In order to check the pulses being received by each input during a wash cycle, the BrightLogic unit provides a pulse test facility (see page 35). This must however be used before any of the pumps have been “enabled”, with all of the pulse counts set to “ALL” (default).

Example:

If the pulse count is set to 01, the pump will run when the first signal is received. All further signals to the displayed input will be ignored until the unit has re-set (see page 24).

Setting:

Use the **UP** and **DOWN** keys to select the required pulse count for the displayed input.

Press the **FWD/ACCEPT** key to confirm the selection and move to the first of the PUMP SETUP screens.

Caution:

If the pulse count of a pump is set to all, multi triggering may occur with some laundry machines.

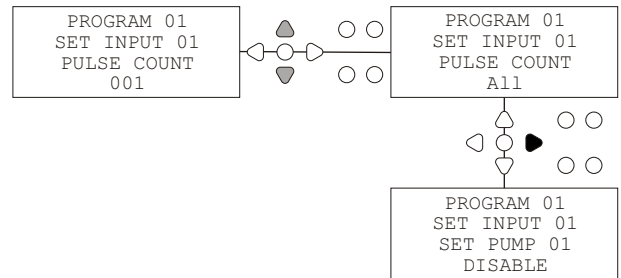

By default, all of the pumps will initially be set to “DISABLE” on all of the inputs.

Use the **FWD/ACCEPT** and **BACK** keys to select the pump that you wish to run when a signal is received on the selected input.

Use the **UP** and **DOWN** keys to change the condition of the selected pump from “DISABLE” to “ENABLE”.

Use the **FWD/ACCEPT** key to confirm your selection and move to the PUMP DELAY TIME screen for the pump you have just enabled.

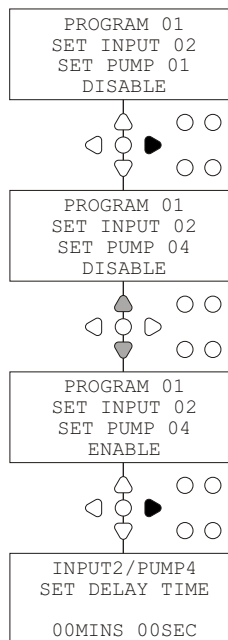

PROGRAMMING - PUMP DELAY TIME

The BrightLogic software, allows the user to program a time delay between the unit receiving a signal from the host machine, and the appropriate pump running.

This would be used to reduce the chance of neat products (such as Hypochlorite bleach) being introduced over dry clothing, as this may cause the clothes to be damaged.

Setting:

Use the **UP** and **DOWN** keys to alter the delay time selection. Use the **FWD/ACCEPT** key to confirm your selection and move on to the RUN TIME/DOSAGE screen.

Note:

If a flow rate has been set for the selected pump, the next screen will be the DOSAGE screen (see page 23).
If no flowrate has been set, the next screen will be the RUN TIME screen (see page 23).

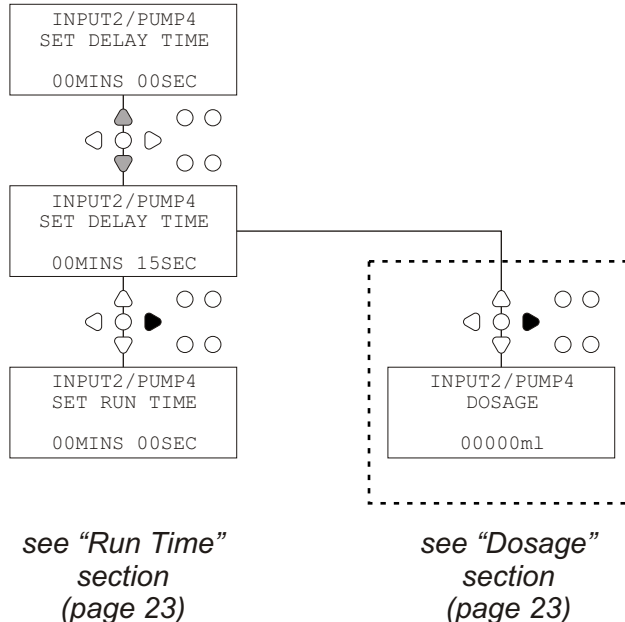

see “Run Time” section (page 23)

see “Dosage” section (page 23)

If a flow rate has been set for the pump, the unit will automatically ask for a dosage to be selected.

The dosage is the volume of product (in ml or fl/oz), which you wish to be dispensed into the host machine, during a single cycle.

Setting:

Use the **UP** and **DOWN** keys to select the desired dosage (ml or fl/oz).

Use the **FWD/ACCEPT** key to confirm your selection and move to the PUMP ENABLE screen for the next pump (see page 22).

Once all the pumps have been set for the selected input, press the **SEE/JUMP** key to move onto the next input (see page 20).

If all of the inputs have been programmed, press the **SEE/JUMP** key again to move onto the RESET OPTIONS screen.

Note:

Units will be in fl/oz if American language is selected.

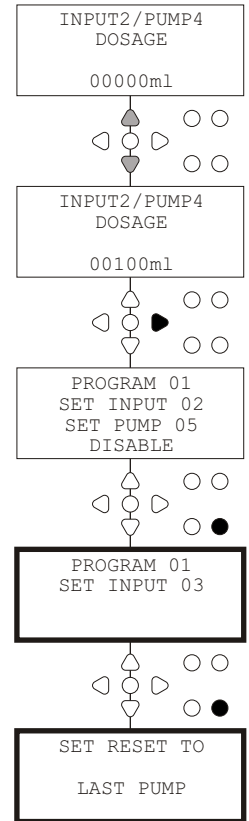

PROGRAMMING - RUN TIME

If no flow rate has been set, the unit will require a run time to be selected.

The run time is the time for which the selected pump will need to run, in order to dispense the volume of product for a single cycle.

Setting:

Use the **UP** and **DOWN** keys to alter the amount of time the selected pump will run for.

Use the **FWD/ACCEPT** key to confirm your selection and move to the PUMP ENABLE screen for the next pump (see page 22).

Once all the pumps have been set for the selected input, press the **SEE/JUMP** key to move onto the next input (see page 20).

If all of the inputs have been programmed, press the **SEE/JUMP** key again to move onto the RESET OPTIONS screen.

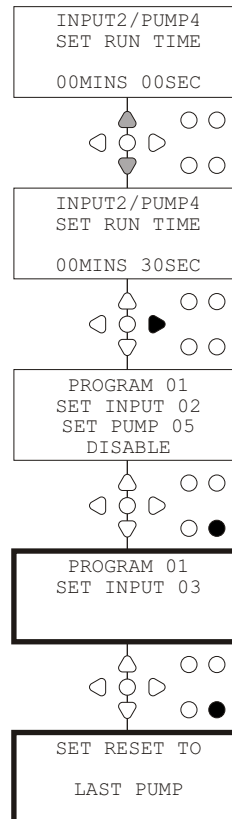

Alternatively:

Press the **TEST** button and the pump will run.

Once the required volume of product has been dispensed, press and hold the **TEST** button for 2 seconds.

The unit will automatically record the time taken.

The BrightLogic Laundry unit, will allow the user to set the condition under which the unit will reset. This condition defaults to LAST PUMP, but has three possibilities:

LAST PUMP

The unit will re-set after the last pump (usually the fabric softener) has run.

FEATURE OFF

This feature would usually be used on tunnel machines, with the PULSE COUNT set to "ALL". In this mode, the Formula Select can be used to change the program at any time a pump is not running.

INPUT 10

If fabric softener is not being used, the signal from the softener solenoid can be taken to input 10. The unit will then reset after it has received a signal to input 10 on the A & B rails, even though no softener is being dispensed.

Cycle timeout

The system has a 1 hour automatic reset which activates after a program has been selected but no trigger received within 1 hour. This menu allows the 1 hour time to be adjusted in increments of 5 minutes from 5 - 995 minutes

Setting:

Use the **UP** and **DOWN** keys to select the required reset condition. Use the **FWD/ACCEPT** key to confirm your selection

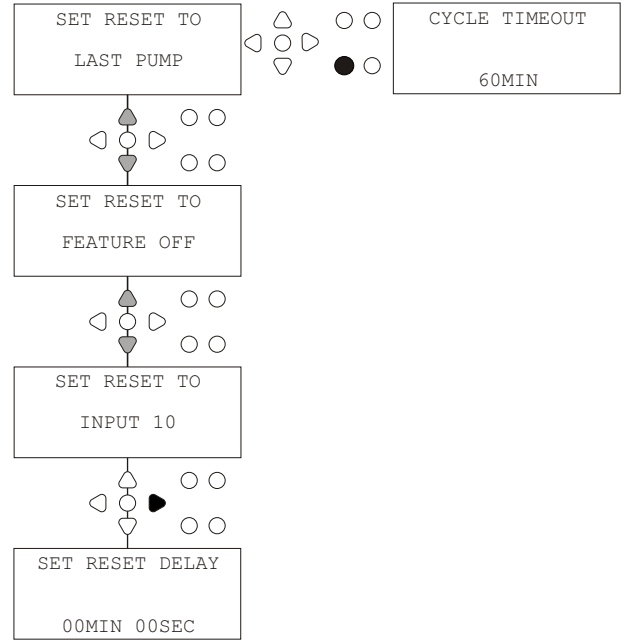

PROGRAMMING - RESET DELAY

The RESET DELAY, allows the user to set the time that the unit will wait, before it resets, ready for the next wash.

Use the **UP** and **DOWN** keys to select the required delay time.

Use the **FWD/ACCEPT** key to confirm your selection and move on to the FORMULA SELECT screens.

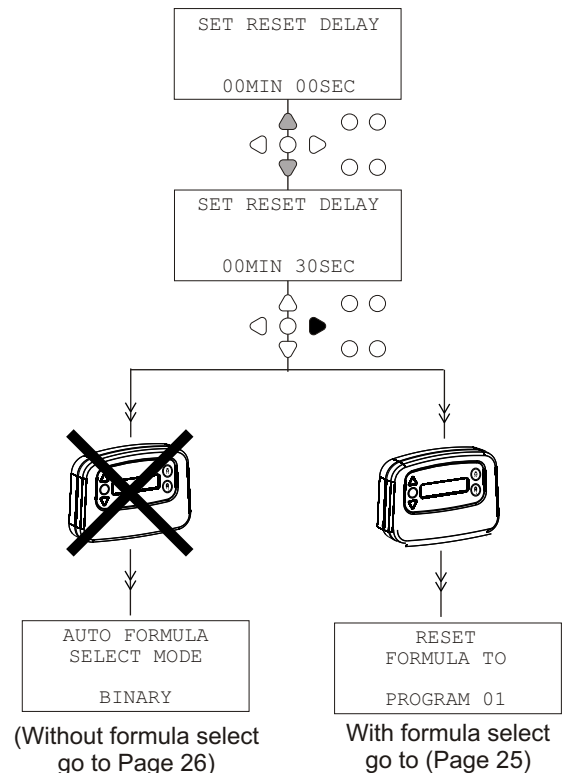

The BrightLogic Laundry unit, with a formula select module installed will allow the user to set the condition under which the program will reset.

If there is a reset delay set the program will reset after this period.

This condition defaults to PROGRAM 01, but has four possibilities:

PROGRAM 01

The program will reset to program 01. (default)

PROGRAM 00

The program will reset to program to 00. This is a blank program with no settings.

ANY PROGRAM

The program can be reset to any program which has settings saved to it.

PREVIOUS PROGRAM

The program will reset to the program it has just washed with. (Eg. If program 8 was used then it will reset to program 8)

Setting:

Use the **UP** and **DOWN** keys to select the required reset condition. Use the **FWD/ACCEPT** key to confirm your selection and move on to the SUMMARY screen.

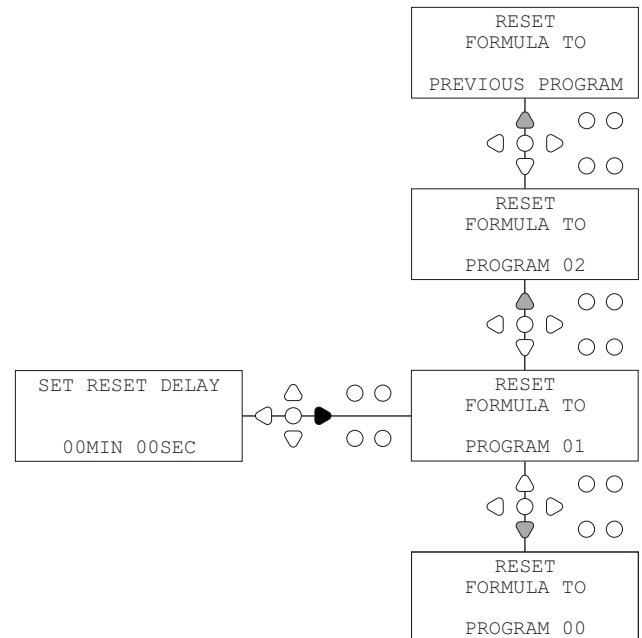

For use with computer controlled (intelligent) host machines only, the Auto Formula Select mode allows automatic selection of programs (formulas) without the need for a Formula Select module. There is two modes to choose from a Binary mode or a Timed mode.

Setting:

Use the UP and DOWN keys to select between BINARY and TIMED modes. Press FWD/ACCEPT key to confirm your selection.

BINARY MODE

To Activate:

The AUTO FORMULA SELECT MODE will activate automatically when the first signal to the unit (after it has reset) is to AFS input.

After receiving the signal to AFS, the host machine then has the set up time to signal the unit with the desired program number.

This is done by signalling the inputs 1-5, and works on a binary basis: -

- Input 1 = Binary 1
- Input 2 = Binary 2
- Input 3 = Binary 4
- Input 4 = Binary 8
- Input 5 = Binary 16

(All signals must be present for the duration of the signal acceptance time. See page 15)

Example:

If program number 10 is needed, the host machine must signal inputs 2 and 4 within the set up time of signalling AFS.

- Input 2 = Binary 2
- Input 4 = Binary 8
- 2 + 8 = 10, so program 10 will be selected.

After the set up time has ended, the unit will display the selected program number in the top right corner of the screen. The inputs can then be signalled, and the pumps will run as normal, in the selected program.

Setting:

Use the UP and DOWN keys to alter the amount of time the set up of signals require. Press FWD/ACCEPT key to confirm your selection and move to the SUMMARY screen.

Note:

If a unit receives a combination of signals which is in excess of the maximum number of programs (e.g. input 4 + input 5 = 8 + 16 = 24) an error message will be shown on screen (see opposite) and the unit will default to program 01.

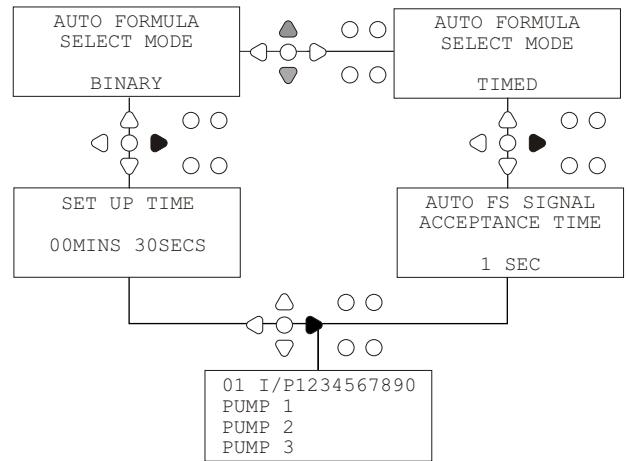

```
00000 L10 01
*** ** * ** *
AUTO-FS ERROR
UNKNOWN PROGRAM
```

Note: Software version 3.0 onwards

A signal received to AFS input will first reset the system if the previous program was not completed. The same signal will then be used:

Timed Mode: to select the program number based on the duration of the signal

Binary Mode: to initiate the set up time

TIMED MODE

To Activate:

The AUTO FORMULA SELECT MODE will activate automatically when the first signal to the unit (after it has reset) is to AFS.

After receiving the signal to AFS, the next signal to AFS will then be timed to determine what program number is required. So if the signal is present for 5 seconds then it will select program 5. The acceptance time can be altered so if set to 2 sec then it will need to be present for 10 seconds to select program 5.

After the signal is removed, the unit will display the selected program number in the top right corner of the screen.

The inputs can then be signalled, and the pumps will run as normal, in the selected program.

Setting:

Use the UP and DOWN keys to alter the acceptance time. Press FWD/ACCEPT key to confirm your selection and move to the SUMMARY screen.

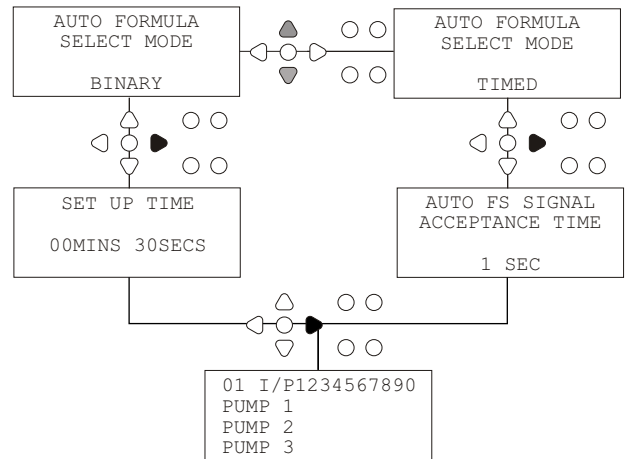

PROGRAMMING - SUMMARY SCREEN

The summary screen allows you to view which inputs have been assigned to which pumps. (Remember an input can be assigned to more than one pump, and a pump can be made to run on more than one input)

The screen will display the current program number in the top left corner of the screen, the inputs 1-10 along the top and the pumps down the left.

Use the **UP** and **DOWN** keys to scroll through the SUMMARY screen. Cursors will indicate which inputs are assigned to which pumps.

Use the **PROGRAM** key to view the summary screen of other programs (formulas) you may have entered.

If the settings are correct, press the **FWD/ACCEPT** key to move to the SAVE SETTINGS screen.

Alternatively:

If the settings are not correct, use the **BACK** key to re-trace your steps and amend any settings you wish to change. Or press the **SEE/JUMP** key to return to the SETTINGS screen (see page 15).

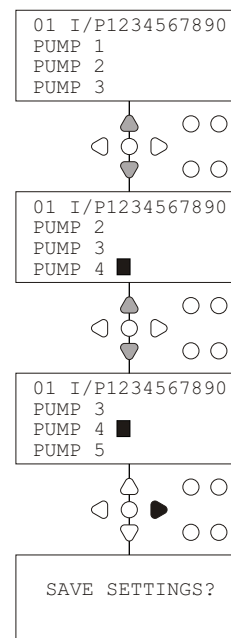

At the SAVE SETTINGS screen, press the **FWD/ACCEPT** key to confirm and save all of your programs.

The SETTINGS SAVED message will now appear for a few seconds while the unit overwrites the previous settings.

The unit will then revert to its operational mode, and display the default screen.

Note:

If the unit is left in any part of the PROGRAM MODE, with no keys pressed for 30 mins, it will automatically save the changes and revert to operational mode.

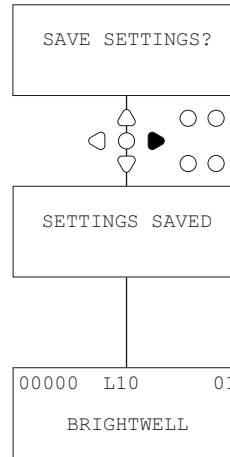

PROGRAMMING - CREATING ADDITIONAL PROGRAMS

Enter the program as described on page 20.

From the INPUT SELECTION screen, Press the **PROGRAM** key to increment the program number. Enter the parameters for additional programs in the same manor as before (see page 20 to 26).

Note:

With the new Brightlogic software, it is no longer necessary to assign programs in chronological order.

Example:

If the wash room personnel only use two programs on the host machine, Program 5 - Heavy Soil and Program 9 - Delicates. The Brightlogic unit can be set up with only two programs, Program 5 for heavy soil and Program 9 for delicates.

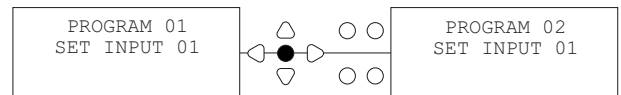

From the Input Selection screen, Use the **PROGRAM** key to increment to the program number you wish to create.

To access the COPY PROGRAM function, press the **FWD/ACCEPT** and **PROGRAM** keys simultaneously.

Using the **UP** and **DOWN** keys, select the program number that you wish to copy. Press the **FWD/ACCEPT** key to copy the displayed program.

Press the **FWD/ACCEPT** key once more to confirm. The information will then be copied into the selected program number.

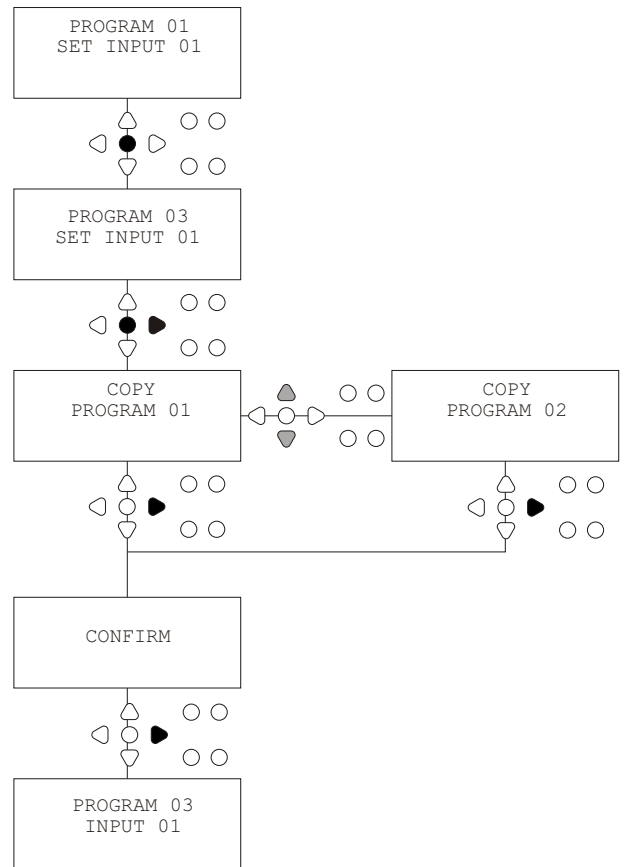

PROGRAMMING - Deleting an Existing Program

From the Input Selection screen, press the **PROGRAM** key to increment the program number to the one you wish to delete.

Press the **BACK** and **PROGRAM** keys simultaneously.

Using the **UP** and **DOWN** keys, select whether to delete the current program or ALL programs.

Press the **FWD/ACCEPT** key. You will be asked to CONFIRM your selection.

Press the **FWD/ACCEPT** key once more to confirm.

All the Pumps for the selected program will be disabled and all setting will return to their default.

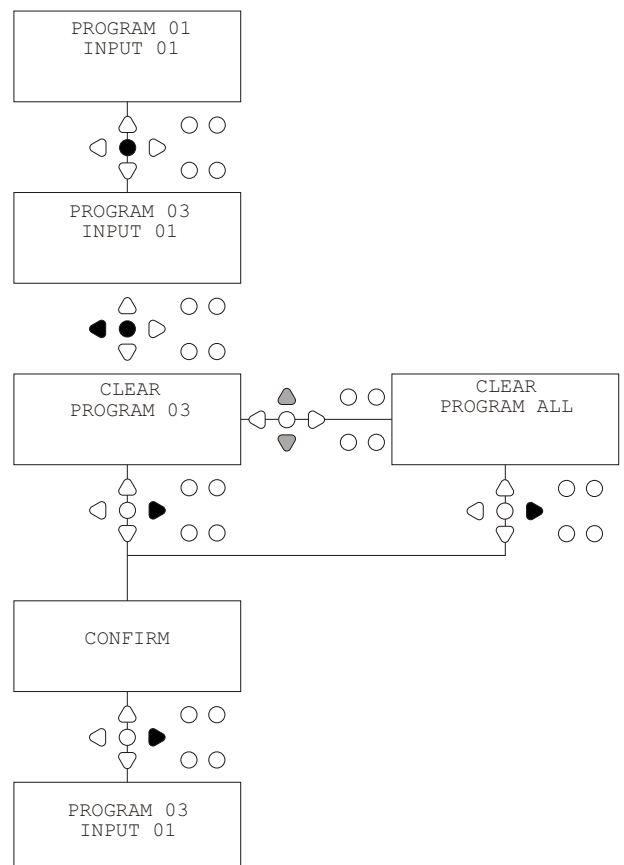

The CYCLE COUNTERS mode allows the user to view the run time and cycles information for each pump. The total number of cycles performed by the unit can also be viewed.

At each screen, the **UP** and **DOWN** keys can be used to toggle between the RUN TIME and CYCLES counters.

All of the counters can be individually reset to “zero” by holding down the **UP** and **DOWN** keys together.

Note:

By resetting the “Total Cycles” counter, all other counters will be reset.

Accessing:

Access the CYCLE COUNTERS mode as described on page 15.

From the CYCLE COUNTERS screen, press the **FWD/ACCEPT** key once to view the TOTAL CYCLES screen.

TOTAL CYCLES - (run by a specific program)

The display will default to program 01, however other programs can be selected by pressing the **PROGRAM** key. Press the **FWD/ACCEPT** key again to view the TOTAL RUN TIME/CYCLES screen.

TOTAL RUN TIME/CYCLES - (run by each pump)

Use the **FWD/ACCEPT** key to cycle through all of the pumps. Once all pumps have been viewed, press the **FWD/ACCEPT** key again to view the RUN TIME/CYCLES screen.

RUN TIME/CYCLES - (per program)

The display will default to the program that was selected at the total cycles screen. Other programs can be selected by pressing the **PROGRAM** key. Press the **FWD/ACCEPT** key to cycle through the pumps. Once all of the pumps have been viewed, press the **FWD/ACCEPT** key to return the unit to service.

Counter Maximums:

- Cycles = 50,000
- Run-time = 49,000Hrs 59Mins
- Chemical Dosage = 50,000 litres
= 50,000 fl/oz

Note:

If a Flowrate has been set instead of a Pump Speed, the unit will display TOTAL FLOW QUANTITY instead of RUN TIME.

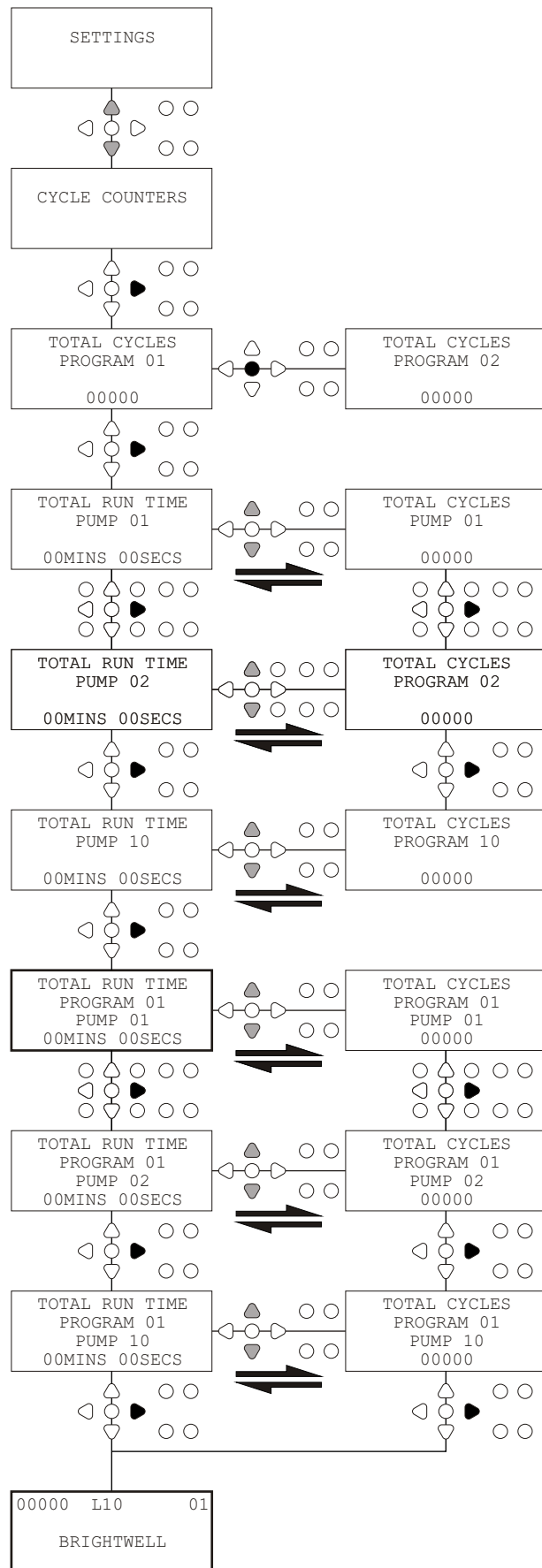

The BrightLogic unit will default to its “Standard” operational mode.

However if the host machine is “Intelligent” (ie. computer controlled), it may be preferable to use the RELAY mode

(Descriptions of both of the unit’s operational modes can be found on page 3)

To access the RELAY mode:

From the default screen (see opposite) hold down the **TEST** key, then press the **SEE/JUMP** keys for 2 seconds.

Enter the correct four-digit access code using the **UP** and **DOWN** keys to select a number and the **FWD/ACCEPT** key to move on (as shown on page 15).

Use the **UP** and **DOWN** keys to toggle between the two operational modes.

Once the required operational mode is displayed, press the **FWD/ACCEPT** key to confirm your selection.

The selected mode will be displayed on screen briefly, while the unit changes mode.

The unit will then revert to the default screen for the selected mode (see opposite).

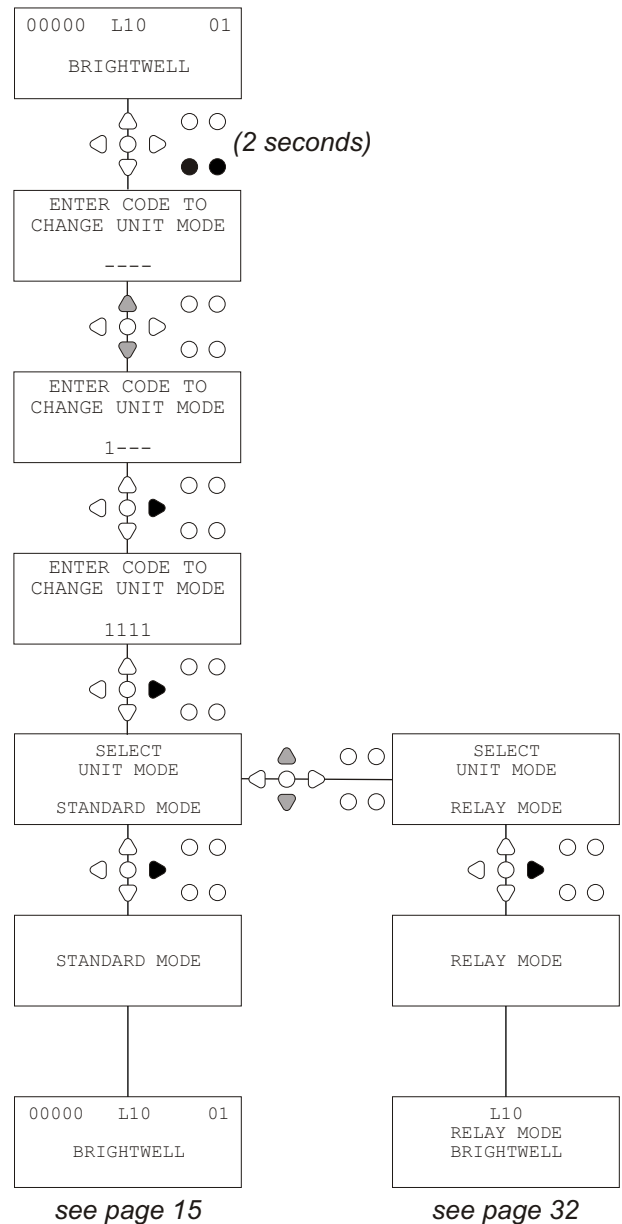

Access the program mode by entering the four-digit security code (see page 15).

Assign the pumps to the required manifolds (see page 16). Press the **FWD/ACCEPT** key to confirm and move to the next screen.

Set the Flush Valve Mode and Flush Time - if required (see pages 16 to 18). Press the **FWD/ACCEPT** key to confirm and move to the next screen.

The BrightLogic software allows the user to program each pump with a Flowrate instead of a pump speed. This is so the counters will display a TOTAL DOSAGE rather than a TOTAL RUN TIME.

Flowrate:

Measure and set both the flowrate for the displayed pump, and the date (see page 19). Press the **FWD/ACCEPT** key to confirm and move onto the TOTAL RUN TIME screen for that pump.

Pump Speed:

Set the speed required for the displayed pump (see page 18). Press the **FWD/ACCEPT** key to confirm and move onto the RUN TIME screen for that pump.

At the TOTAL RUN TIME screen, press the **UP** and **DOWN** keys to toggle between the TOTAL RUN TIME (or CHEMICAL DOSAGE if a flow rate has been set), and TOTAL CYCLES. These counters can be “zeroed” by simultaneously holding down the **UP** and **DOWN** keys.

Press the **FWD/ACCEPT** key to confirm and move on to the settings for the next pump.

Set the speeds for the remaining pumps in the same way as above.

When all of the pumps have been programmed, the SAVE SETTINGS? prompt will appear.

Press the **FWD/ACCEPT** key to confirm the settings and return the unit to service.

Alternatively:

If the settings are not as you want, use the **BACK** key to retrace your steps and amend any settings you wish to change.

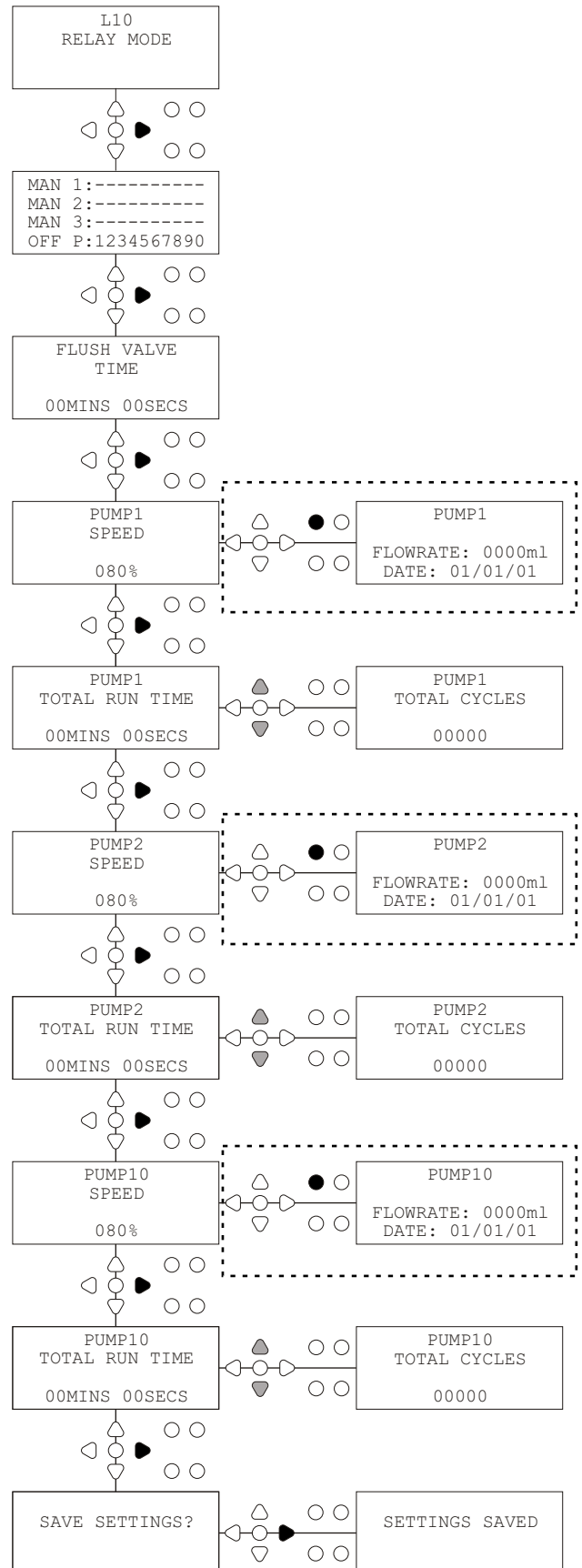

The BrightLogic unit will default to its "Standard" operational mode.

(Descriptions of both of the unit's operational modes can be found on page 3)

To access the LEVELS mode:

From the default screen (see opposite) hold down the **TEST** key, then press the **SEE/JUMP** keys for 2 seconds.

Enter the correct four-digit access code using the **UP** and **DOWN** keys to select a number and the **FWD/ACCEPT** key to move on (as shown on page 15).

Use the **UP** and **DOWN** keys to toggle between the two operational modes. Once the required operational mode is displayed, press the **FWD/ACCEPT** key to confirm your selection.

The selected mode will be displayed on screen briefly, while the unit changes mode.

The unit will then revert to the default screen for the selected mode (see opposite).

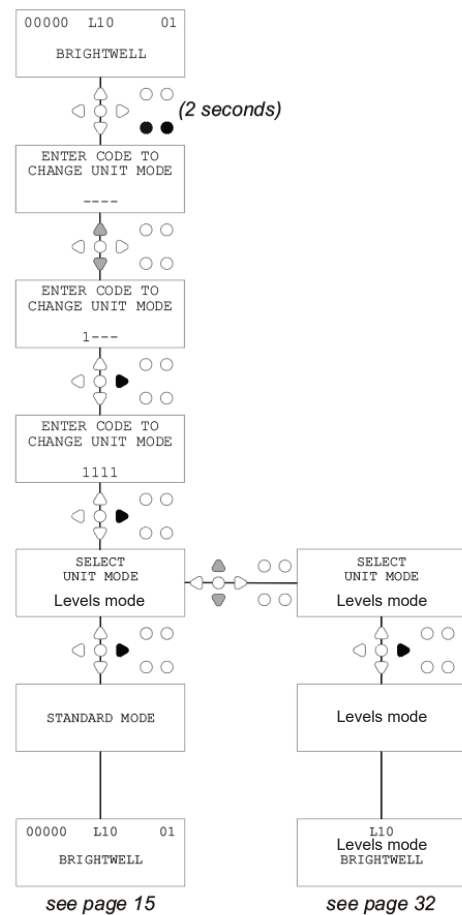

***For programming Levels mode please go to PAGE 15**

From the default screen, press the **FWD/ACCEPT** key.

Enter the correct four-digit access code using the **UP** and **DOWN** keys to select a number and the **FWD/ACCEPT** key to move on/confirm.

Press **UP** and **DOWN** to select the "Wireless USB settings" option, and press **FWD/ACCEPT** to accept and move on the next screen.

Press **UP** and **DOWN** to select your desired RF channel and then press **FWD/ACCEPT** to accept and return to the default screen.

Note: If there are more than one unit in close proximity all the units will need to be set to different RF channels. This will prevent settings being written to the wrong unit.

If a Blue tooth device is attached to the Rs232 output on the PCB the blue tooth channel select menu will appear after the RF channel

For further information on Wireless USB settings and installation see instruction manual B989.

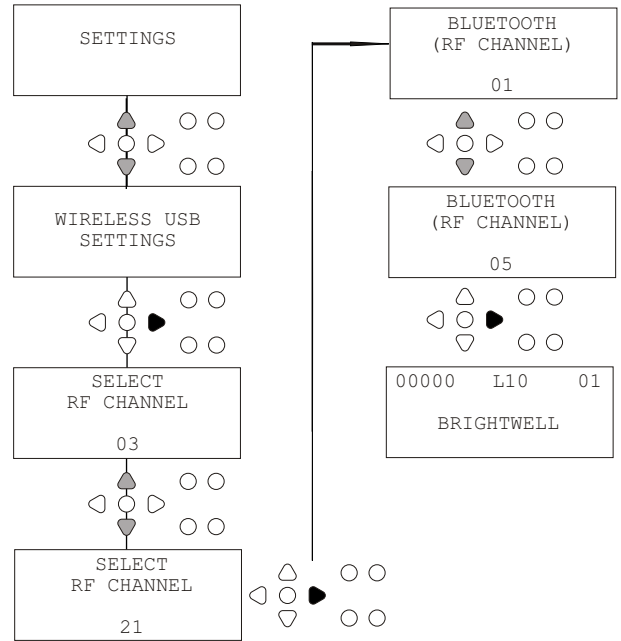

PRIMING PUMPS - FROM THE UNIT

To prime the pumps from the Keypad, press the **PRIME** key to display the Prime Mode screen.

Use the **UP** and **DOWN** keys to select the pump that you wish to prime.

Press and hold the **PROGRAM** key to prime the selected pump. Use the **UP** and **DOWN** keys to select the next pump that you wish to prime, and repeat as above.

Once all of the pumps have been primed, press the **PRIME** key to return the unit to service. (The unit will return to service automatically if no keys are pressed for 10 seconds)

Alternatively:

If the pumps are connected to a manifold then the FLUSH VALVE PRIME may be enabled.

At the PRIME screen, press the **TEST** key once, the "FV PRIME ENABLED" text will appear on screen and the allocated flush valve will prime with the pump.

(Alternatively, press and hold the **TEST** key for 2 seconds to prime all flush valves independently of the pumps)

Note:

This feature can be disabled from the TEST MODE (see page 35).

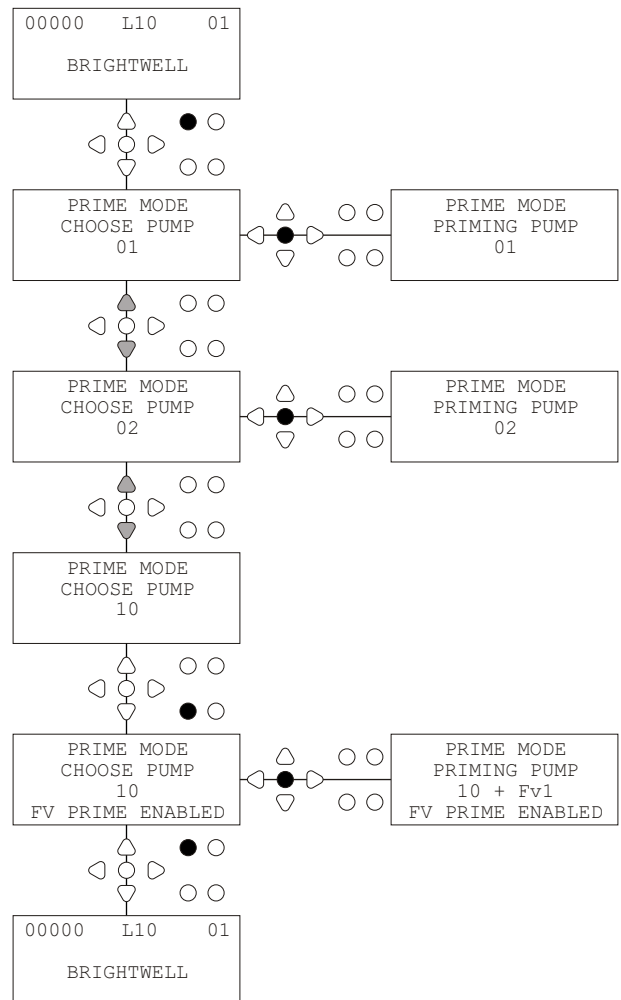

All pumps can be individually stopped from the keypad. Press the **PUMP STOP** key to display the PUMP STOP MODE screen.

Use the **FOWARD/ACCEPT** and **BACK** keys to highlight the pump that needs to be turned off/on. Use the **UP/DOWN** keys to change the position of the pumps cursor to the "ON" or "OFF" rail.

Press the **PUMP STOP** key to return to the default screen. (The unit will return to service automatically if no keys are pressed for 10 seconds) Any pumps that are OFF will be displayed, flashing, at the bottom of the default screen.

Note:
This feature can be disabled from the TEST MODE (see page 35).

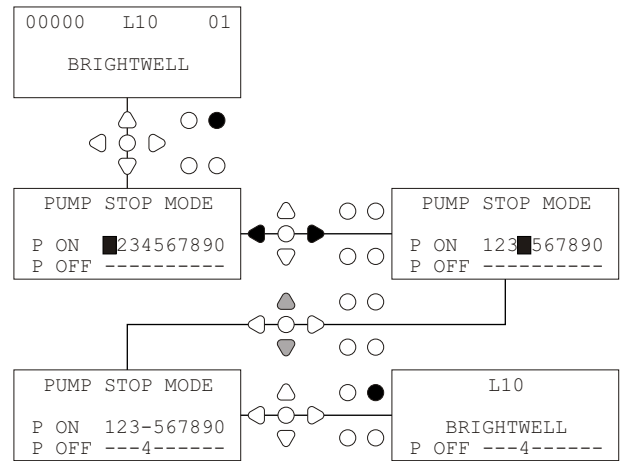

VIEW MODE

If you wish to view the Program Settings and Cycle Counters without editing them, this can be done through the VIEW MODE.

From the default screen, press the **SEE/JUMP** key to enter the VIEW MODE. Use the **FWD/ACCEPT** and **SEE/JUMP** keys to scroll through the Settings or Cycle Counters as in the PROGRAM MODE.

Only ENABLED pumps will be shown

Note:
This feature can be disabled from the TEST MODE (see page 35).

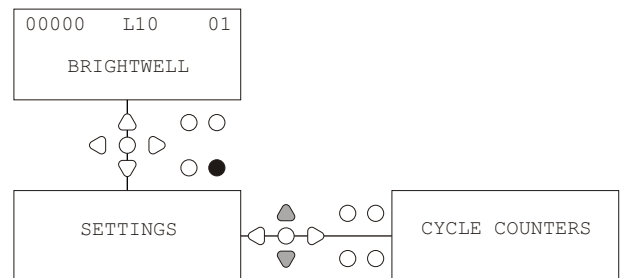

In order to check that all of the required inputs are receiving signals (and to test for inputs which are receiving multiple signals), the BrightLogic software provides a PULSE TEST screen.

To Access:

From the default screen, press the **TEST** key.

The screen will display a numerical counter for each of the inputs, which will show the number of signals which have been accepted on each input (i.e. Signals, which exceed the signal acceptance time), up to the selected pulse count.

i.e. If the pulse count is set to 01, the first signal will be displayed, all others will be ignored until the unit has reset. If the pulse count is set to "ALL", every signal will be counted.

All of the counters will reset when the unit does (see page 24).

The screen will also show the unit receiving signals in "real time", via the 10 cursors along the bottom of the screen, which will illuminate when any signal is present.

This saves the engineer from having to use a voltmeter to check each input.

To return to the default screen, press the **TEST** key again.

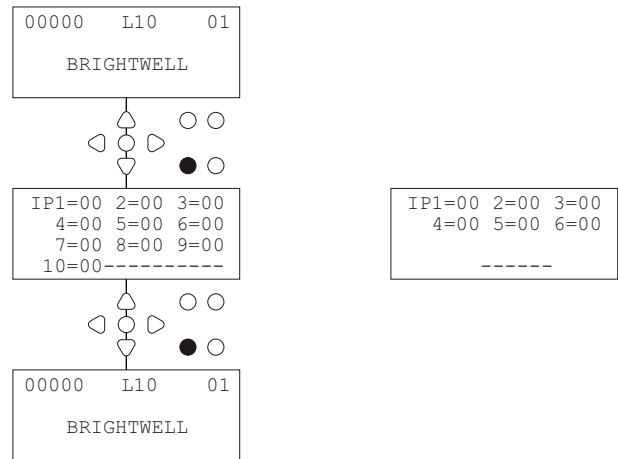

SOFTWARE/SERIAL NUMBER

In order to view the unique serial number of the unit, along with the BrightLogic software version number and RF channel:

From the default screen, press either the **UP** or **DOWN** key.

The display will change to show the: -

RF Channel (selected channel)

S/W VERS: (software version number)

S/N: (units unique serial number)

The unit will return to the default screen after 5 seconds.

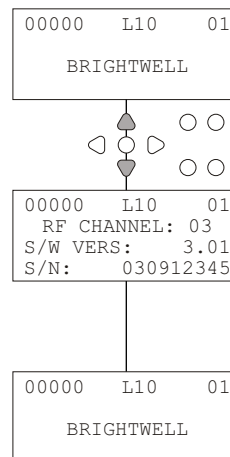

To access the TEST MODE, first de-power the unit. Then, while holding down the **TEST** key, power the unit back up. When the unit has initiated, it will be in TEST MODE.

To check the keypad is functioning correctly:

Press each button in turn, and its function will appear on the display, indicating that the key is working. Each key will function as normal, if held down for two seconds.

To check the unit is functioning as desired:

Press and hold the **TEST** key for 2 seconds, and the PULSE COUNT/SIGNAL screen will be displayed. The inputs can then be triggered, and will display if a signal is present. If a signal is present for more than one second, the pump will run for 2 seconds and the pulse counter will increment by one.

To disable the PUMP STOP mode:

When in TEST MODE, hold down the **FWD/ACCEPT** key for 2 seconds. Input the security access code as normal. The PUMP STOP - DISABLE screen will be shown.

From the PUMP STOP - DISABLE screen, Use the **UP/DOWN** keys to ENABLE or DISABLE the pump stop mode. Press the **FWD/ACCEPT** key to confirm your selection and move on to the PRIME - DISABLE screen.

To disable the PRIME mode:

From the PRIME - DISABLE screen, Use the **UP/DOWN** keys to ENABLE or DISABLE the prime mode. Press the **FWD/ACCEPT** key to confirm your selection and move on to the VIEW MODE - DISABLE screen.

To disable the VIEW mode:

From the VIEW MODE - DISABLE screen, Use the **UP/DOWN** keys to ENABLE or DISABLE the view mode. Press the **FWD/ACCEPT** key to confirm your selection and move back to the TEST MODE screen.

To exit the TEST MODE, de-power the unit, then power it back up as normal.

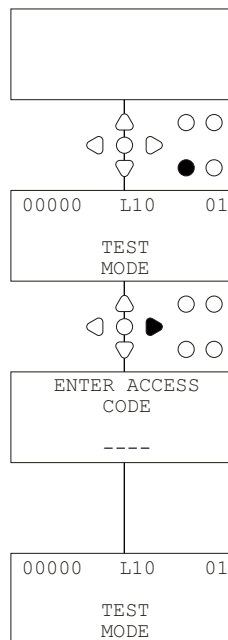

Signal Acceptance - Length of time that a signal must be present on an Input before it is acknowledged.

Flush Valve - 24V DC output to control a Flush Solenoid (maximum 36W). This output is active throughout the operation of any pump.

Delay Time - Adjustable time period between a signal being acknowledged and a pump beginning its operation.

Speed - Adjustable rotation rate at which each pump will operate.

Flowrate - The speed at which product is dispensed from a pump. Specified in ml/min.

Run-Time - Adjustable time period for which a pump will operate.

Dosage - The volume of product which is required to be dosed into a wash cycle by each pump.

Pulse - Signal number that a pump is to operate on. Pulse counter returns to zero when the unit resets.

Reset Delay - Adjustable time period at the end of the wash cycle before the dispenser resets. The Reset Delay begins after the operation of the final pump (ie: Pump 8, on an 8-Pump unit).

Relay - Operational mode allowing the Pumps to run as if they were directly driven from the input signals.

Safety Stop - Water sensor input to detect the presence of water within a Manifold.

Cycle Counters - Provides a record of the number of cycles and length of time that has been completed by each pump and program.

Prime - Run the pump to fill the suction and delivery tubes.

Pump Stop - Switch the pumps off in case of failure and to prevent operation during maintenance.

Power Supply	Voltage	100V to 240V AC
	Frequency	50 - 60Hz
	Current	Logic @240V L2 - 0.14A L4 - 0.16A L6 - 0.27A L8 - 0.38A L10 - 0.50A

Power								
SUPPLY	MODEL	MAX	SUPPLY	MODEL	MAX	SUPPLY	MODEL	MAX
WL2	2 PUMP	31.2W	WH1	1 PUMP HF	31.2W	WHD1	1 PUMP MEM	31.2W
WL4	4 PUMP	51.2W	WH2	2 PUMP HF	51.2W	WHD2	2 PUMP MEM	51.2W
WL6	6 PUMP	71.2W	WH4	4 PUMP HF	91.2W	WHD4	4 PUMP MEM	91.2W
WL8	8 PUMP	91.2W	WH6	6 PUMP HF	111.2W	WHD6	6 PUMP MEM	111.2W
WL10	10 PUMP	131.2W	WH8	8 PUMP HF	131.2W	WHD8	8 PUMP MEM	131.2W

Output	Flush Valve	24V DC, 1.25A (30W) MAX.
	Buzzer/Lamp	24V DC, 500mA (10W) MAX.

Fusing	Resettable 0.55A
---------------	------------------

Motor	Brushless - 24V DC, 600mA
--------------	---------------------------

Pump	6.4mm Silicone - 100% = 350ml/min / 30% = 102ml/min (Flowrate taken using water)
-------------	---

Enclosure	GFPP - IP44
------------------	-------------

Weight (approx.)	Logic	L2 - 2.1Kg	L4 - 2.3kg	L6 - 3.4kg
			L8 - 4.5kg	L10 - 5.6kg

- IEC 60335-1:2010+A2:2016 ● IEC 60335-1:2010+A2:2016 ● EN 62311:2008 ● EN 61000-3-2:2019 ● EN 61000-3-3:2013+A1:2019
- EN 61000-6-1:2019 ● EN 61000-6-3:2007+A1:2011 ● ETSI EN 301 489-1 V2.2.3 ● ETSI EN 301 489-17 V3.2.4

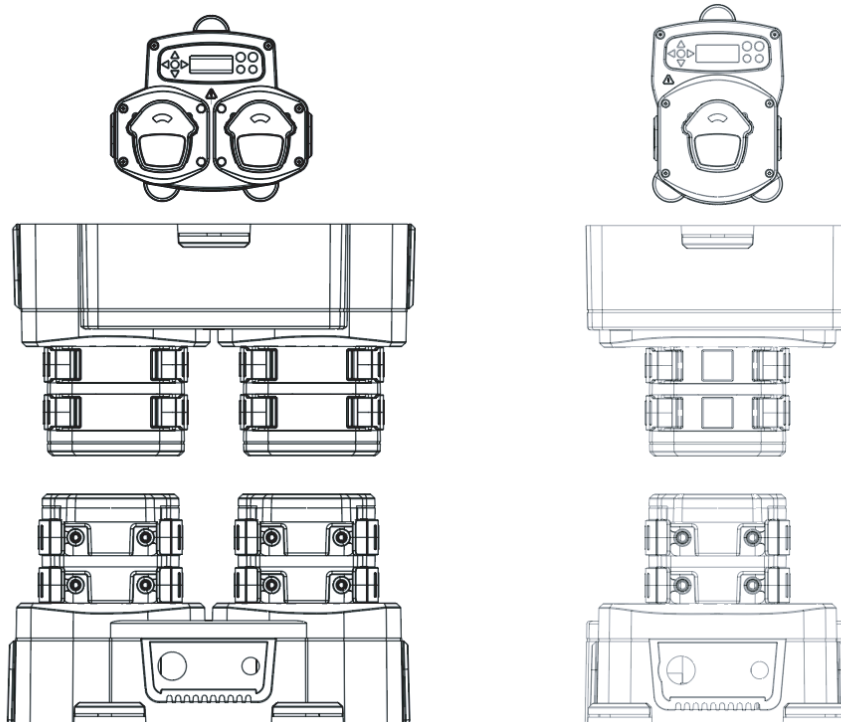

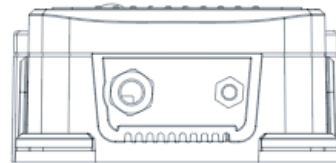
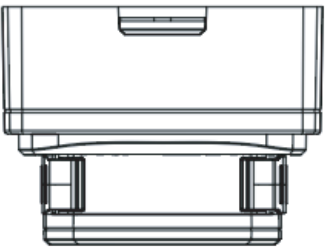
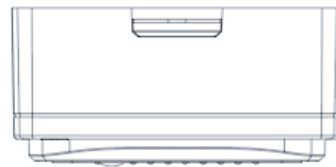
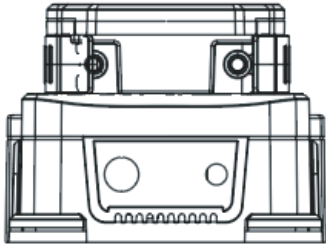

Power Supply	Voltage	24V DC (supplied by unit)
Display		16 x 2 LCD display
Enclosure		GFPP
Weight (approx.)		Module - 0.3kg (including cable)
Cable		6 Core > Length = 10 Metres

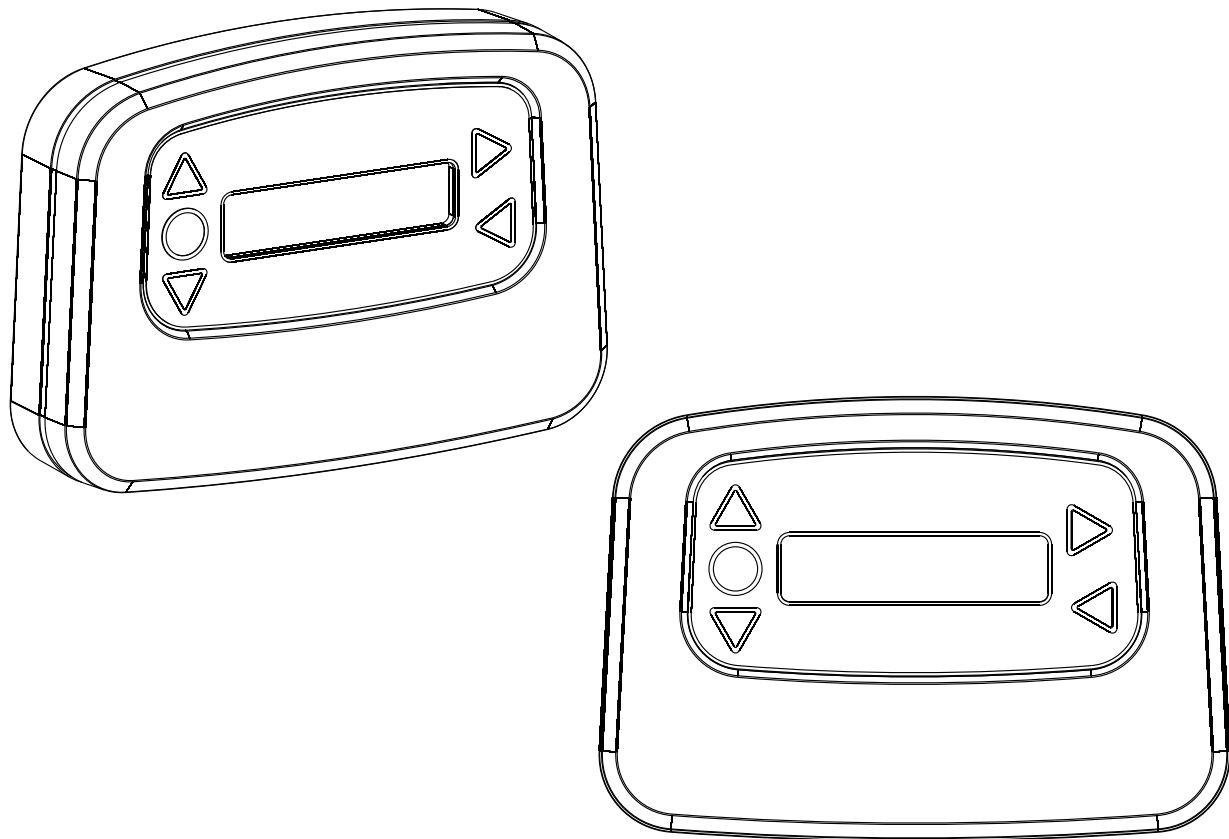

SPECIFICATION

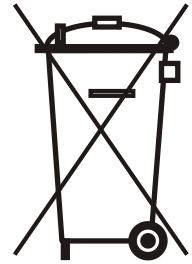

GB **Environment protection first !**
Your appliance contains valuable materials which can be recovered or recycled.

IRL
Leave it at a local civic waste collection point.

F **Participons à la protection de L'environnement**
Votre appareil contient de nombreux matériaux valorisables ou recyclables.

Confiez celui-ci dans un point de collecte ou à défaut dans un centre service agréé pour que son traitement soit effectué.

D **Schützen Sie die Umwelt !**
Ihr Gerät enthält mehrere unterschiedliche, wiederverwertbare Wertstoffe.

A
Bitte geben Sie Ihr Gerät zum Entsorgen nicht in den Hausmüll, sondern bringen Sie es zu einer speziellen Entsorgungsstelle für Elektrokleingeräte (Wertstoffhof).

E **ii Participe en la conservación del medio ambiente !!**
Su electrodoméstico contiene materiales recuperables y/o reciclables.

Entréguelo al final de su vida útil, en un Centro de Recogida Especifico o en uno de nuestros Servicios Oficiales Post Venta donde será tratado de forma adecuada.

I **Partecipiamo alla protezione dell'ambiente**
Il vostro apparecchio è composto da diversi materiali che possono essere riciclati.

Lasciatelo in un punto di raccolta o presso un Centro Assistenza Autorizzato.

NL **Wees vriendelijk voor het milieu !**
i Uw apparaat bevat materialen die geschikt zijn voor hergebruik.

Lever het in bij het milieustation in uw gemeente of bij onze technische dienst.

PL **Bierzmy czynny udział w ochronie środowiska !**
Twoje urządzenie jest zbudowane z materiałów, które mogą być poddane ponownemu przetwarzaniu lub recyklingowi.

W tym celu należy je dostarczyć do wyznaczonego punktu zbiórki.

CZ **Podílejme se na ochranu životního prostředí !**
Váš přístroj obsahuje čtené zhodnotitelné nebo recyklovatelné materiály.

Sveřte jej sbernému místu nebo, neexistuje-li, smluvnímu servisnímu středisku, kde a nim bude naloženo odpovídajícím způsobem.

NOTES

Guarantee

All Brightwell dispensers are guaranteed for two years from the date of purchase against defects in materials and faulty workmanship. Peristaltic tubing is not guaranteed.

Chemical compatibility

We are pleased to offer advice on chemical compatibility, however our guarantee does not cover problems caused by chemical incompatibility.

Safety First

Always follow the chemical manufacturers Health and Safety instructions when using chemicals.

Technical and Design specifications

Specifications within this catalogue are subject to alteration without notice.

BRIGHTWELL DISPENSERS LTD

Unit 1, Rich Industrial Estate, Avis Way, Newhaven, East Sussex, BN9 0DU, UK

T +44 (0)1273 513 566 **F** +44 (0)1273 516 134 **E** sales@brightwell.co.uk **W** brightwell.co.uk

VAT No: GB 100 1998 47. Company registration No: 0661996. Registered in England.

Brightwell Dispensers Ltd is a Bright-Tech Investments Ltd Company