

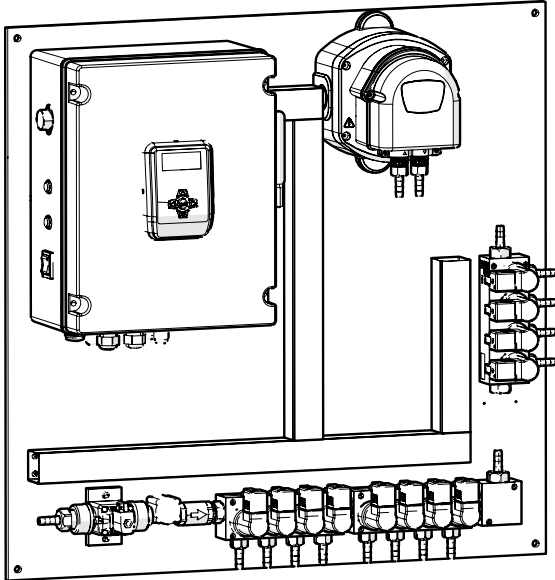

MULTIPLEX 1

LAUNDRY DOSING SYSTEM INDUSTRIAL

PRODUCT DATASHEET



Description

The Multiplex 1 unit is designed to cater to a smaller range of laundry sizes, serving establishments with up to 5 washing machines. With safety as a top priority, the Multiplex dosing system incorporates several key features to ensure peace of mind for operators. From rigorous leak and water testing protocols to comprehensive chemical compatibility checks, Multiplex guarantees a secure dosing routine. Its innovative design also includes continuous channel cleaning with water, effectively minimising maintenance requirements and ensuring uninterrupted operation. The unit's compact build and efficient performance make it an excellent choice for smaller laundromats or facilities seeking reliable and low-maintenance solutions.

Technical Specifications

| | | Value | |
|-------------|------------------------------------|------------------------------------------------------------------------------|-----------------------|
| UNIT | Maximum of products | 8 | |
| | Maximum number of washing machines | 5 | |
| INTERACTION | Functions | Configure Real-Time View Reports Password Management | |
| | Interface | Webserver (Local) Web Portal Basic screen for washer status and alerts | |
| | ELECTRICAL PARAMETERS | Voltage / Frequency | 110-240 VAC / 50-60Hz |
| | | Power | 108W |

T +44 (0) 1273 513566 **E** sales@brightwell.co.uk **W** brightwell.co.uk

Unit 1, Rich Industrial Estate, Avis Way, Newhaven, East Sussex, BN9 0DU, UK

All information in this data sheet is correct at the time of printing and is subject to change without notice.

Technical Specifications

| | | Value |
|------------------------------------|-----------------------------------|---------------------------------------------------------------------|
| WATER | Pressure in dynamic range | 1.5 bar (min) - 3 bar (max) Regulator recommended |
| | Flow rate range | min 2/l per min - max 10/l per min |
| | Inlet connection | Barb 10mm |
| | Maximum temperature | < 30 ° C |
| | Recommended hardness | < 8°dH |
| | Booster tank | Not included. Supplied on request. Recommended. |
| | Water Pressure Regulator | Included |
| PANELS | Material | PVC |
| PUMPS | Number | 1 pump per channel. Main channel: electric diaphragm |
| | Flow rate (with water) | 1.5 litres/minute |
| | Body | PVDF |
| | Membranes | PTFE |
| | Non return valves | PVDF/FFKM |
| PRODUCT/WATER VALVES | Voltage | 24VDC |
| | Body | PP |
| | Closure piston | PTFE |
| | O-rings | FFKM |
| FLOW SENSOR | Standard measuring principle | Water only flow sensor Paddle Sensor (Not included, recommended) |
| | Signal | 9 - 24 VDC PNP |
| | Body | PVC/PA PP |
| | Closure piston | PTFE (Paddle wheel only) |
| | O-rings | NBR FFKM |
| | DOSING | Distribution |
| Outlet barb diameter | | 10 mm |
| Outlet barb material | | PVDF |
| Built-in tubes | | EVA tube 10x16 mm |
| Recommended pipes for installation | | Braided (UK & US) PVC 10x16 |
| CALIBRATION | Mode | Via distributor |
| | Measuring cup type | Not included * recommend |
| FORMULAS | Number | 200 |
| | Dose units | g/kg fl.oz/cw |
| | Maximum number of doses per phase | 6 |

T +44 (0) 1273 513566 **E** sales@brightwell.co.uk **W** brightwell.co.uk

Unit 1, Rich Industrial Estate, Avis Way, Newhaven, East Sussex, BN9 0DU, UK

All information in this data sheet is correct at the time of printing and is subject to change without notice.

| | | Value |
|----------------------|-------------------------|-----------------------------------------------------------------------------------------------------------------------|
| STATISTICS | Data | Cloud synchronisation |
| | | On board storage |
| | | Production in load and cycles |
| | Information | Consumption and product cost |
| | | OEE |
| REMOTE ACCESS | Availability | Alarms |
| | | Data always available on the web portal and the possibility to make changes at any time, with instant synchronisation |
| | Router *Internet access | Not included in the equipment |

Diagram

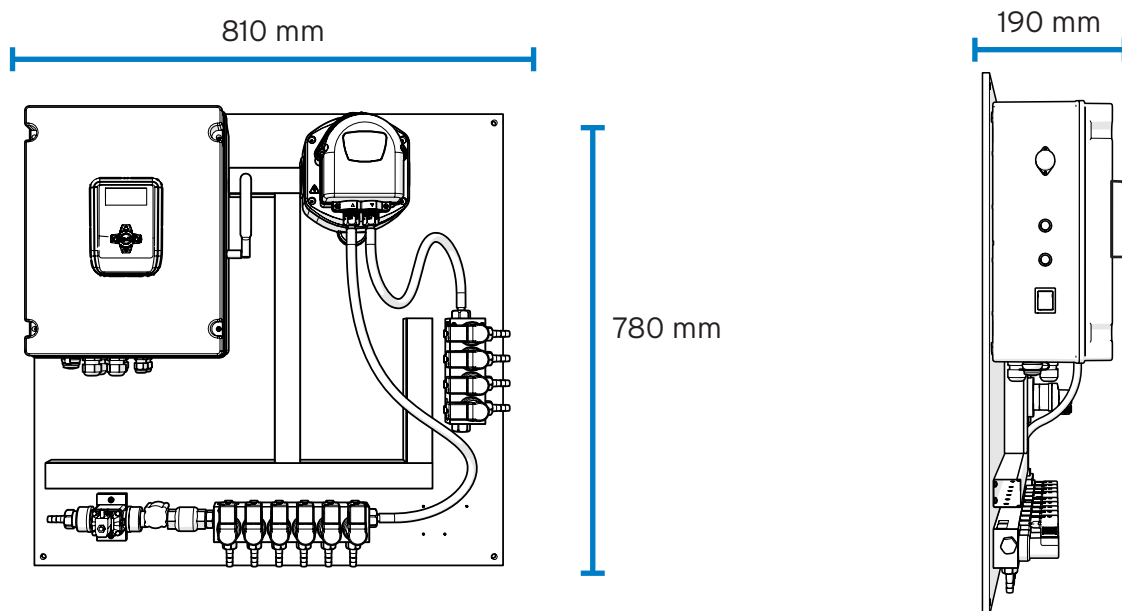

Dimensions

| | |
|--------|--------|
| Width | 810 mm |
| Height | 780 mm |
| Depth | 190 mm |

Weight

| | |
|------|---------|
| Unit | 18.60kg |
|------|---------|

T +44 (0) 1273 513566 **E** sales@brightwell.co.uk **W** brightwell.co.uk

Unit 1, Rich Industrial Estate, Avis Way, Newhaven, East Sussex, BN9 0DU, UK

All information in this data sheet is correct at the time of printing and is subject to change without notice.

Example of Recommended Setup

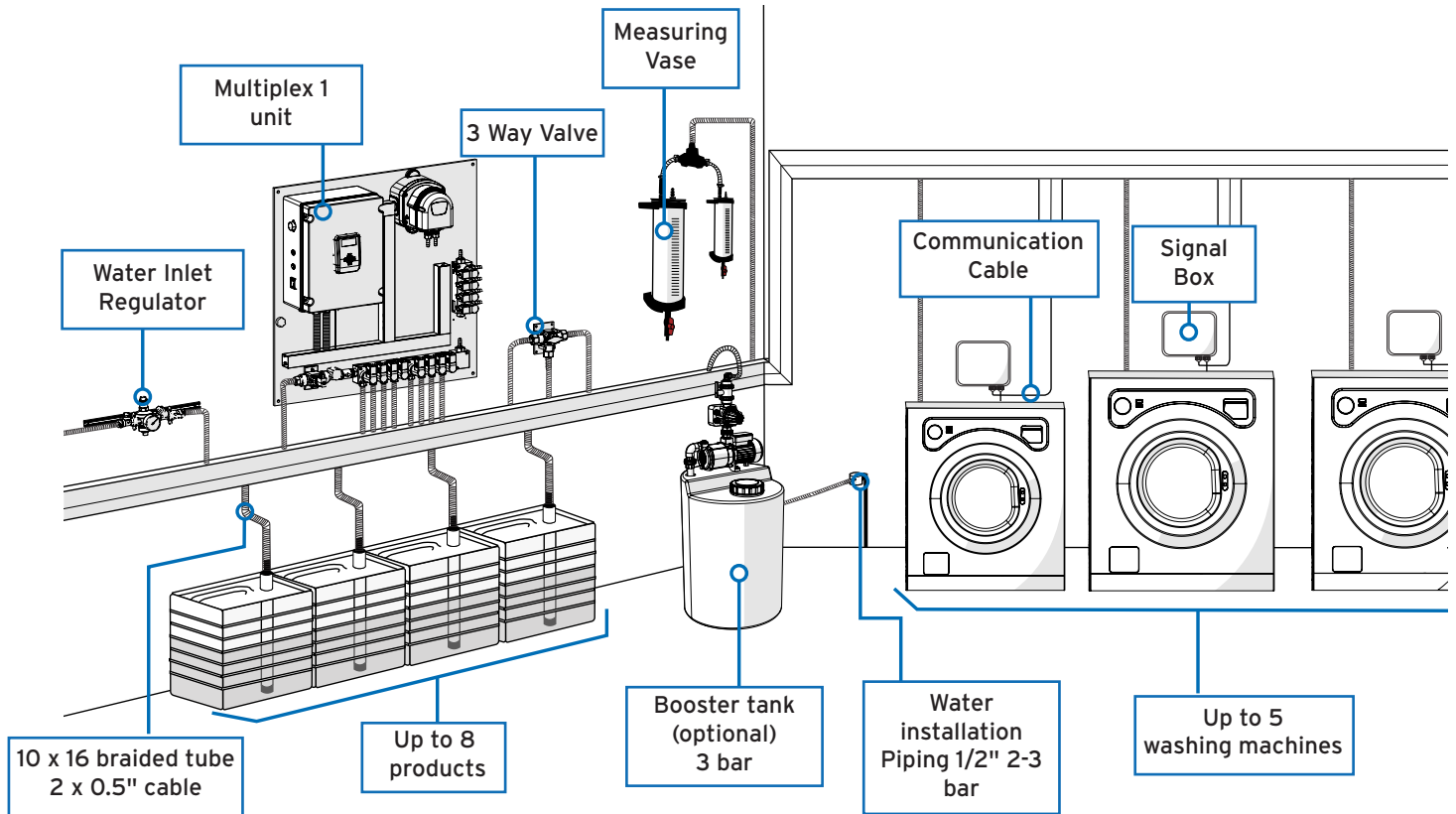

T +44 (0) 1273 513566 **E** sales@brightwell.co.uk **W** brightwell.co.uk

Unit 1, Rich Industrial Estate, Avis Way, Newhaven, East Sussex, BN9 0DU, UK

All information in this data sheet is correct at the time of printing and is subject to change without notice.