

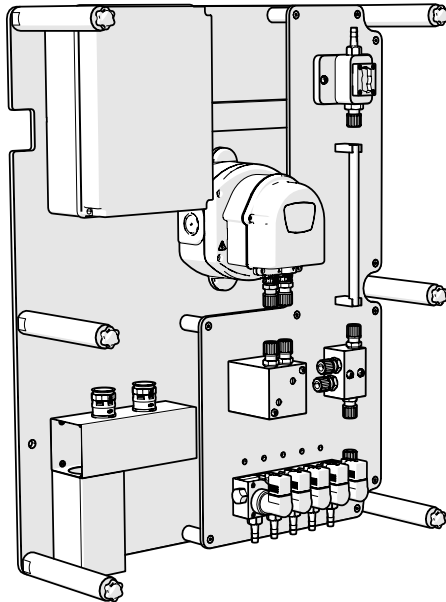

EXPANSION CHANNEL (ELECTRICAL)

TO EXPAND THE CONFIGURATION OF YOUR MULTIPLEX SYSTEM

PRODUCT DATA SHEET



Description

Introducing our innovative Industrial Laundry Expansion Channel, designed to integrate seamlessly with our Multiplex 1 Pro, Multiplex 2 or Multiplex 2 Pro distribution units, revolutionising your laundry operations.

Key Features:

Integration of Electric Solenoids: The expansion channel is equipped with advanced electric solenoids, providing reliable and precise control over the flow of water and detergents. This ensures optimal performance and efficient utilisation of resources in your laundry operations.

Enhanced Configuration Options: 1+1, 2+1 and 4+1 configurations provide tailored solutions for different laundry requirements. Whether you are running a smaller operation or a large-scale industrial facility.

Technical Specifications

		Value
CONFIGURATION	Number of products	1
		2
		4
ELECTRIC PARAMETERS	Voltage	24VDC
	Power	120W
WATER	Pressure in dynamic range	1.5 bar (min) - 3 bar (max) Regulator recommended
	Flow range	min 2l/m - 10l/m max
	Inlet connection	Barb 10mm
	Maximum temperature	< 30 ° C
	Required hardness	< 8°dH
	Booster tank	Not included. Supplied on request. Recommended.

T +44 (0) 1273 513566 E sales@brightwell.co.uk W brightwell.co.uk

Unit 1, Rich Industrial Estate, Avis Way, Newhaven, East Sussex, BN9 0DU, UK

All information in this data sheet is correct at the time of printing and is subject to change without notice.

Technical Specifications

		Value
PANELS	Material	PVC
	Number	1 pump per channel. Main channel: electric diaphragm
PUMPS	Flow rate (with water)	1.5 litres/minute
	Body	PVDF
	Membranes	PTFE
	Check valves	PVDF/FFKM
	Voltage	24VDC
PRODUCT/WATER VALVES	Body	PP
	Closure piston	PTFE
	O-rings	PVDF/FFKM
FLOW METERS	Standard measuring principle	Paddles + Hall effect sensor
	Signal	24 VDC PNP
	Body	PP
	Palettes	PVDF
	O-rings	FKM
	Alternative	*Oval gear not included. Supplied on request. Recommender with chemicals 180cP or higher.
CALIBRATION	Mode	Via distributor
	Measuring vase	Not included * recommended

Diagram

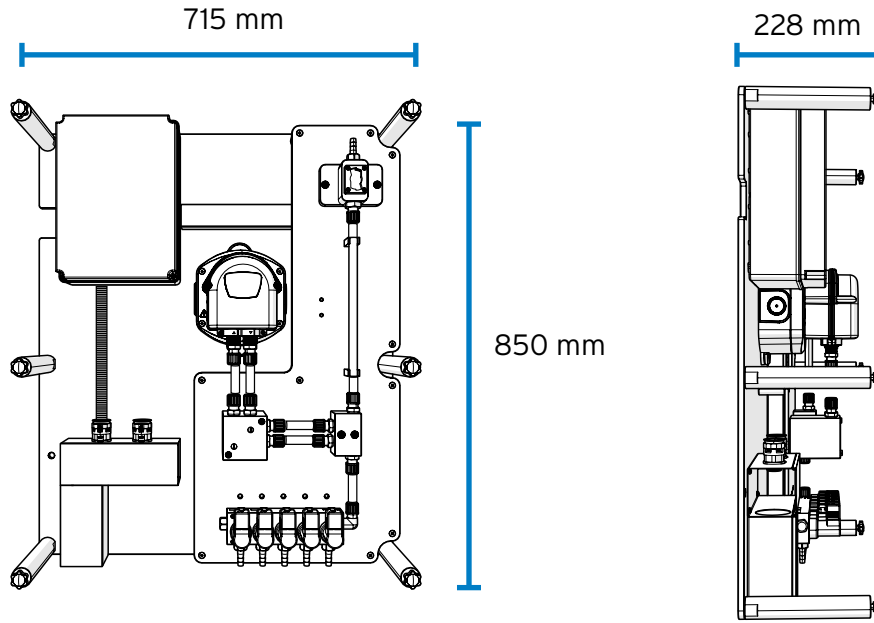

Dimensions

Width	715 mm
Height	850 mm
Depth	228 mm

Weight

Unit	18.6 kg (approx)
------	------------------

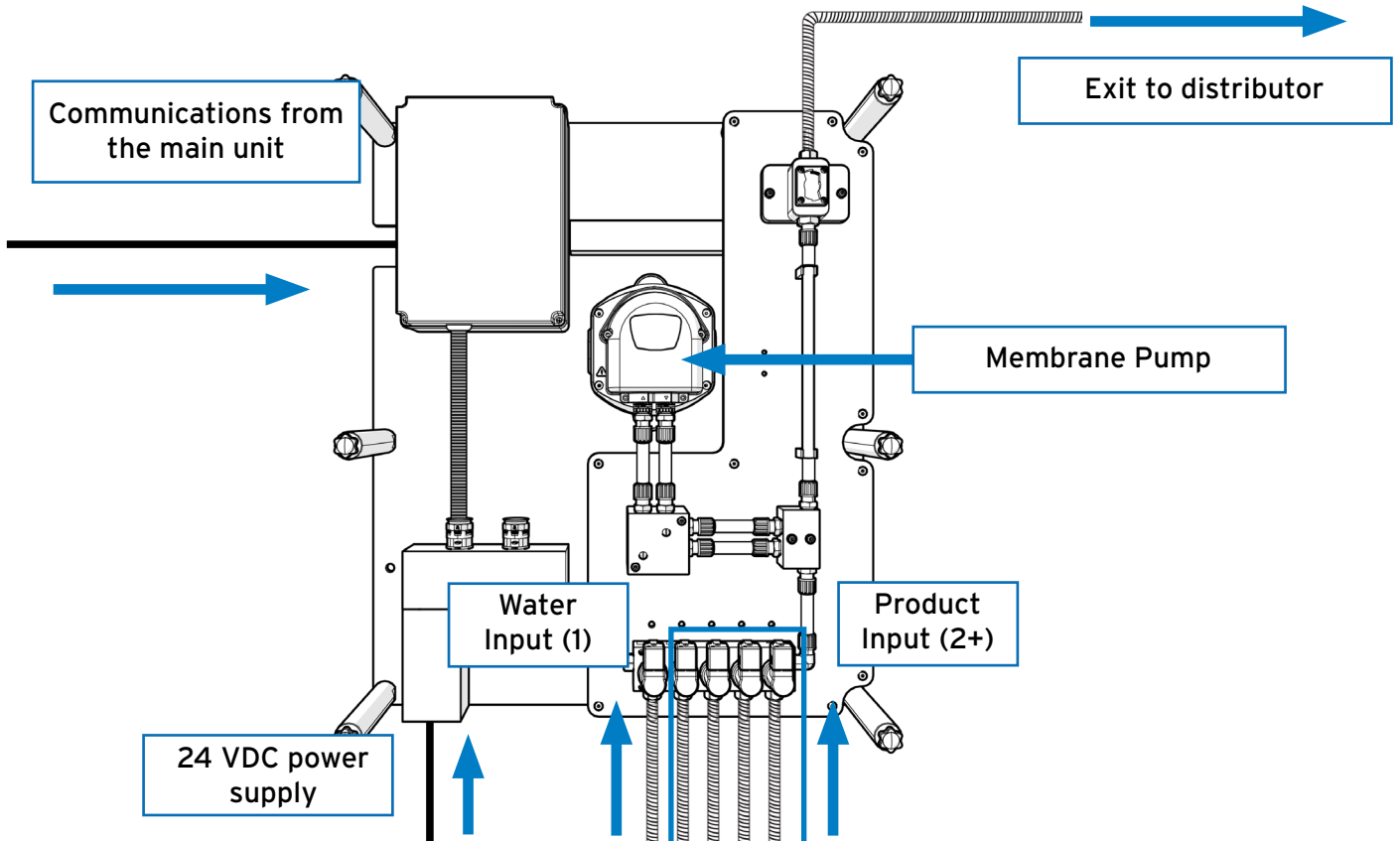

T +44 (0) 1273 513566 E sales@brightwell.co.uk W brightwell.co.uk

Unit 1, Rich Industrial Estate, Avis Way, Newhaven, East Sussex, BN9 0DU, UK

All information in this data sheet is correct at the time of printing and is subject to change without notice.